



## **G2 SECOND GENERATION** **HIGHER EFFICIENCY**



HYDRAULIC REVERSING  
**GEAR PUMPS**



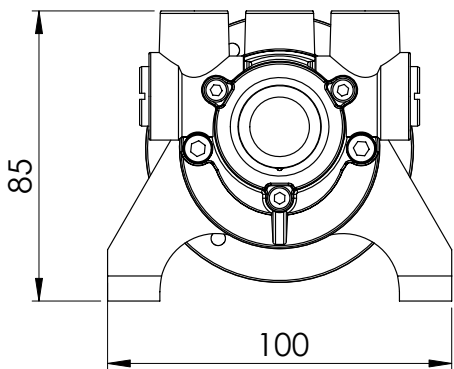
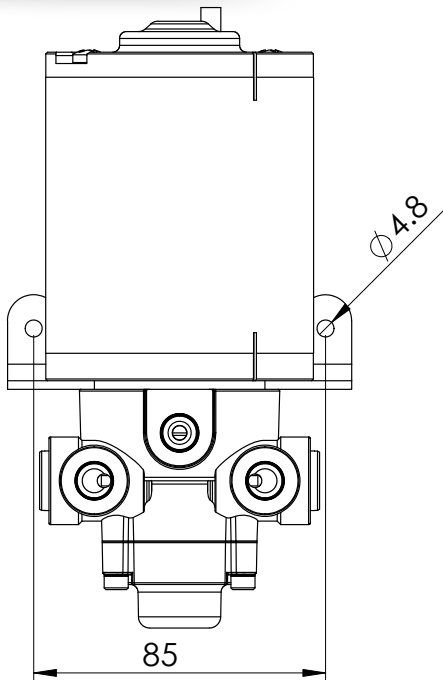

LN	MODEL	OAL (A) (mm)
1	OCTAFG0612	157
2	OCTAFG0624	184
3	OCTAFG1012	168
4	OCTAFG1024	186
5	OCTAFG1612	176
6	OCTAFG1624	189
7	OCTAFG2012	178
8	OCTAFG2024	191
9	OCTAFG3012	214
10	OCTAFG3024	214

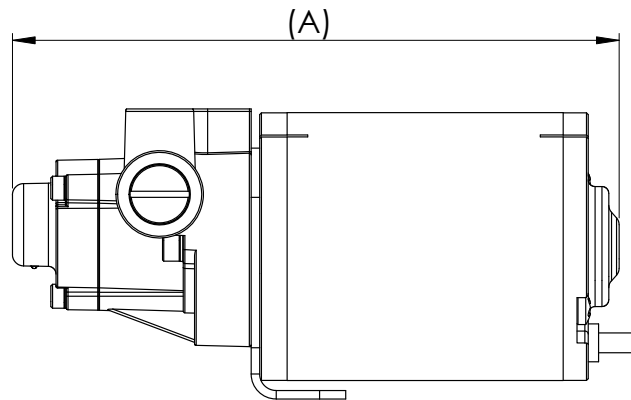

**ACCESSORIES:**

**Fitting Kit OC14342** – 3x 10mm Tube Compression Fittings

**Hose and fitting Kit OC17SUK42** – 3 x 760mm Hoses with assortment of fittings for both NPT and ORB helm connections

**OCTOPUS PRODUCTS**

7733 Progress Way  
Delta, British Columbia  
Canada V4G 1A3

Phone: 1.604.940.2010

Fax: 1.604.952.2650

Email: sales@octopusdrives.com

www.octopusdrives.com

**OCTOPUS EUROPE CB**

PG13 222 La Murta  
Alzira 46600  
Valencia  
Spain

Phone: 00 34 962 120 052

Email: sales@octopuseurope.com

www.octopuseurope.com

