

ALSO AVAILABLE



Jet Thruster

Single | Combi®
Bow or Stern Bow and Stern

Water Jet Thrusters for up to 60 ft boats
The world's most silent and easiest to install inboard thruster systems!



Micro®
Bow or Stern

Water Jet Thruster for 25 - 30 ft boats
The world's smallest and most easy to install inboard thruster system!

www.jetthruster.com

JT-30

JT-50

JT-70

JT-90

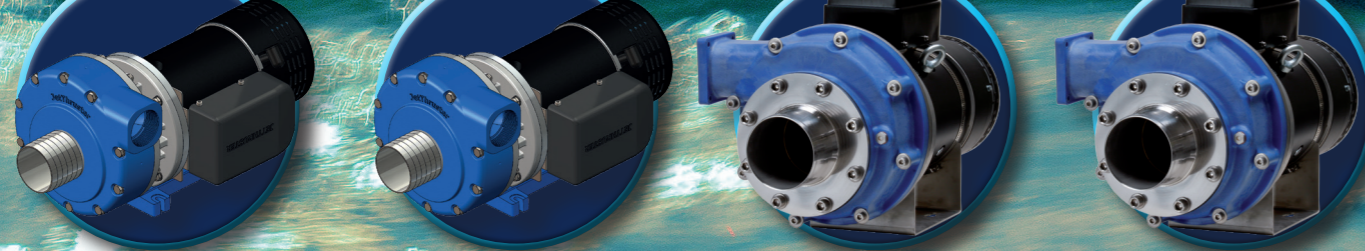

OEM

RETRO FIT

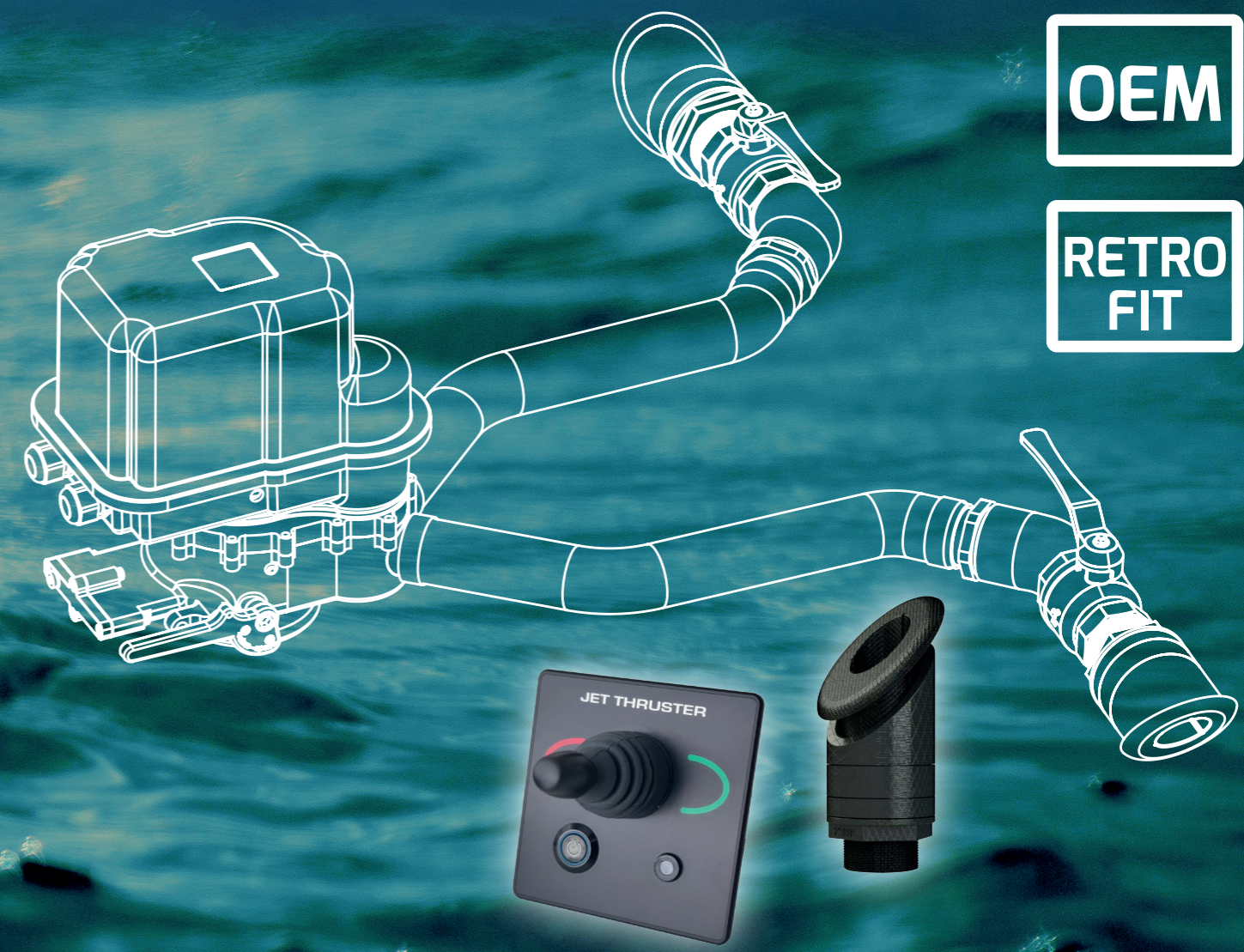

About our Jet Thrusters

JT-30 | JT-50 | JT-70 | JT-90

Jet Thruster Bow and Stern Water jet systems are the alternative to the conventional bow thruster. This Dutch quality product can be easily built into motorboats, sailing yachts and sloops. The powerful water pump and water distribution valves direct the water jet to extremely small skin penetrations. Because there are no moving parts below the waterline, the Jet Thruster is reliable and safe to use.

The Jet Thruster Combi system offers a bow and stern thruster making the boat extremely maneuverable and easy to control. For boats with very limited bow or stern draft, this system is ideally suited.

The Jet Thruster can be built into vessels of 25 to 60 feet. Because no fiberglass or polyester needs to be processed, installation is quick and easy.







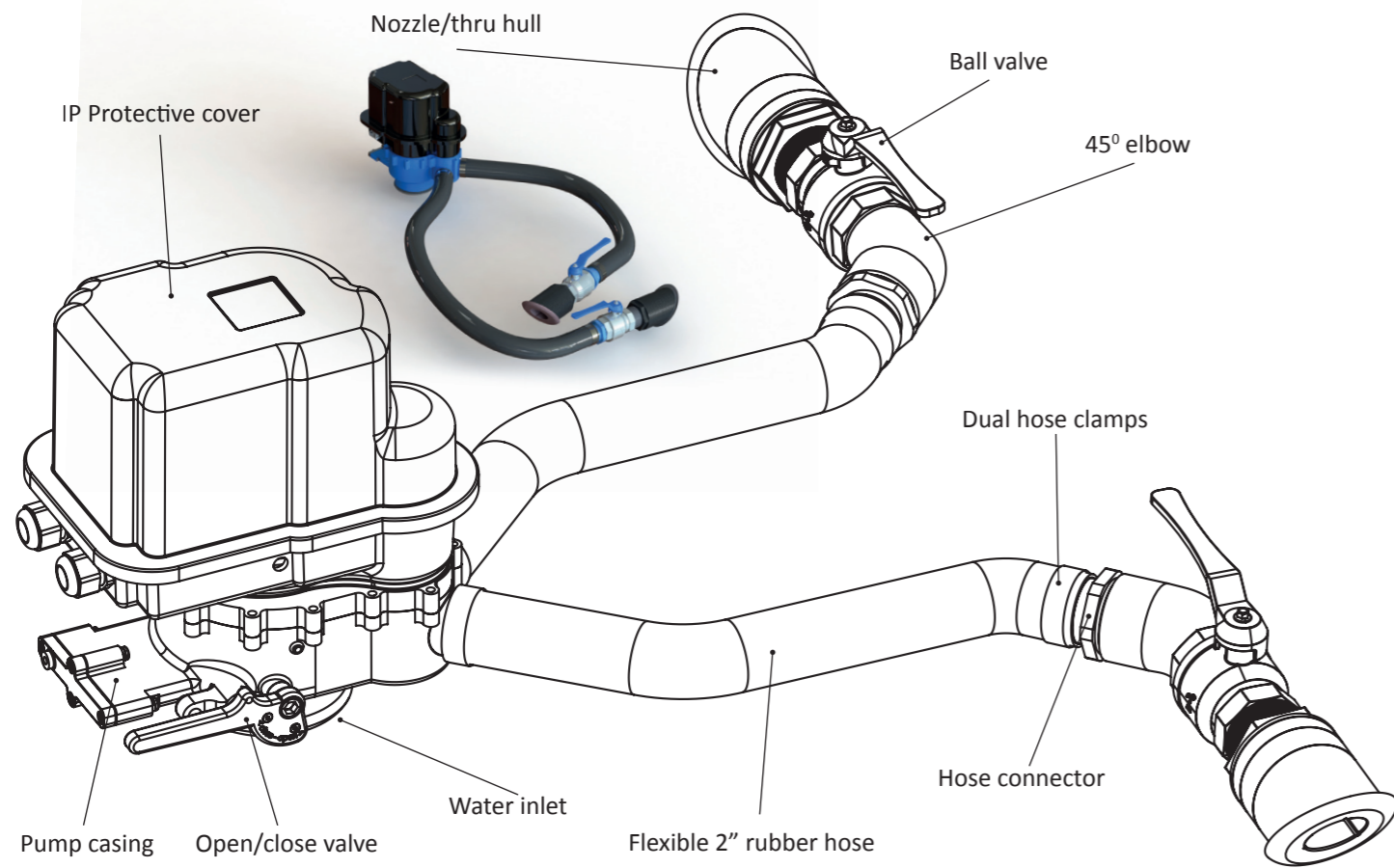

IP protected! - ISO 8846 - Safe for gasoline engine areas

CE Certified

All our products are manufactured according to CE regulations. We keep the rights to change descriptions, graphs or statements, which are required for technical development of our Jet Thruster systems.

HOLLAND MARINE PARTS
WE KEEP YOU MOVING!



- 
Boats up to 30ft
- 
Sailing Boats up to 30ft
- 
Perfect for Motor Boats
- 
Plug & Play!
- 
**DIY proof
Clear instructions!**
- 
Remote control included!
- 
No epoxy or fiberglassing required.
- 
Safe for swimmers and marine life!
- 
**No noise.
Silent operation!**

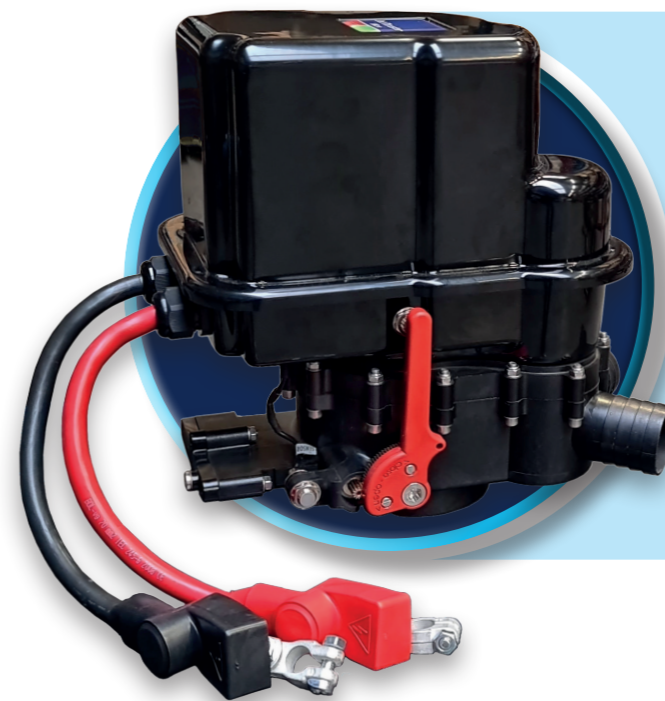

advantages:

- For **shallow draft** (trailable) boats
- **Bow or Stern** thruster
- **No tunnel** required
- **Easy** installation / **DIY** suitable
- Very **small** Nozzles
- **Safe** for Gasoline Engine Areas
- All Composite **corrosion resistant** components
- **Complete package:** Ready for installation

Jet Thruster Micro 66 thrust LBS - 12V

Force	25 Kgf at 10.5V 30 Kgf at 12.5V
Recommended bat. capacity	1 x 12V Optima Yellow Top 75Ah
Water inlet	1 x Ø 90 mm
Water outlet	Nozzle Ø 65 mm
Hose diameter	2" / 51 mm
Weight pump	12kg/24LB

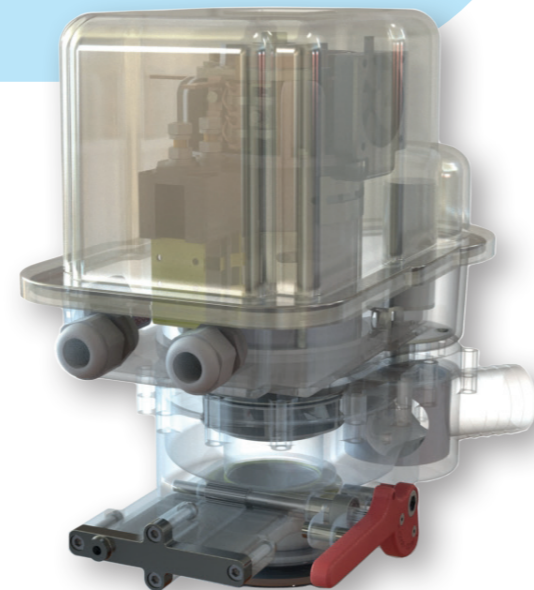
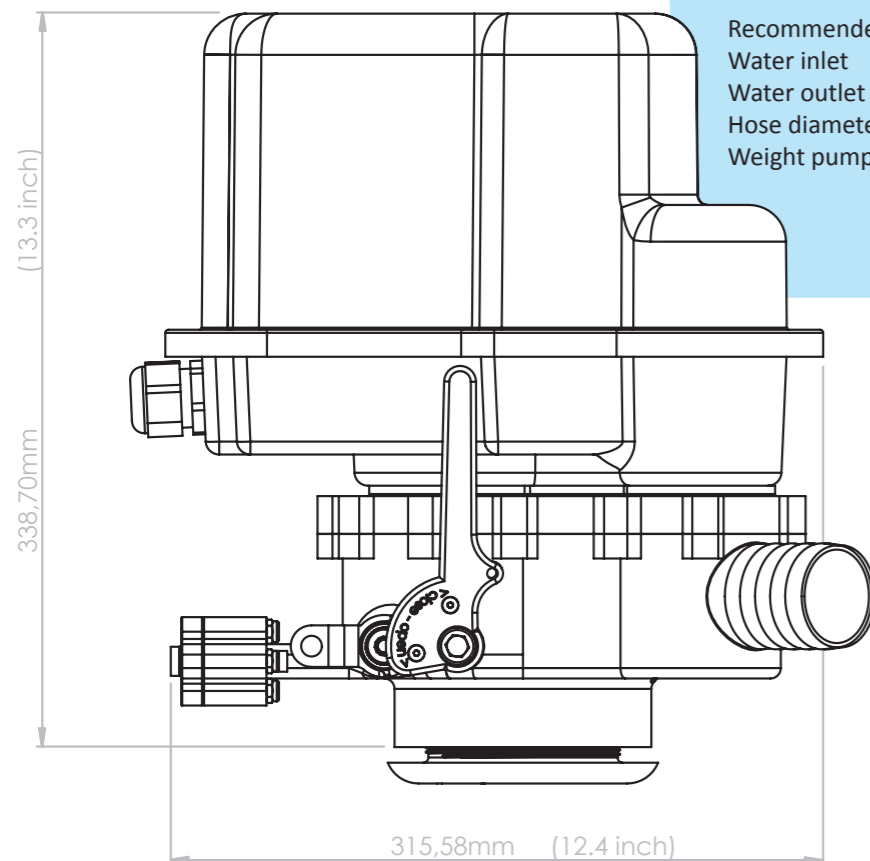

The following items are included in the Installation kit:

- 1x Jet Thruster pump unit incl. battery cable, battery terminals and terminal caps
- 1x Wire harness
- 1x Control panel with Joystick
- 1x Fuse holder incl. ANL fuse
- 1x Hose 5m / 15ft
- 8x Hose clamp SS316
- 2x Hose connector
- 2x Ball Valve
- 2x Nozzle
- 1x Hole saw set
- 1x Installation manual / user guide

