

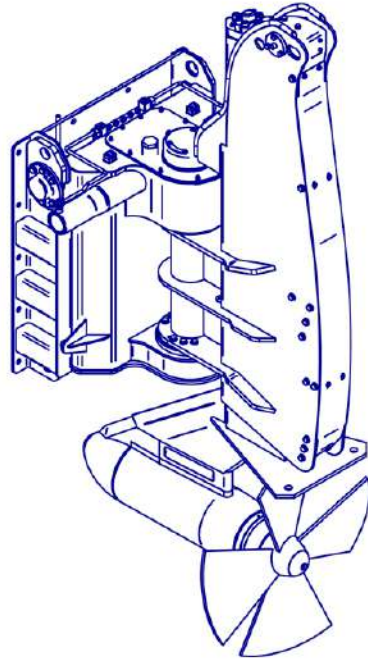

LIFTABLE RUDDER PROPELLER TYPE 2400



CHARACTERISTICS	HD	LD	OPTIONS
Maximum absorbed power / RPM	215kW / 2300 rpm	275kW / 2200 rpm	Hydraulic tilting Steering indicator Lifting indicator Tilting indicator Nozzle
Maximum HP pressure	300 bar	300 bar	
Steering angle	+/- 90°	+/- 90°	
Vertical lifting stroke	1000mm	1000mm	
Tilting angle	50°	50°	
Weight	1500 kg	1500 kg	
Maximum pressure on drain port	2 bar	2 bar	
Maximum auxiliary pressure	150 bar	150 bar	
Propulsive propeller diameter	around 850mm	around 800mm	
Number of blades	4	4	
HP Port	2 x SAE 1"1/2 6000	2 x SAE 1"1/2 6000	
Drain port	1 x MJIC 1"1/16	1 x MJIC 1"1/16	
Auxiliary port	7 x MJIC 9/16	7 x MJIC 9/16	

Type Approval certification by Bureau Veritas



IMPORTANT : Pipes cleanliness should be Class 7 to 8 according to NAS 1638

Document N° DR70N3-20

This document is HYDRO ARMOR property. It can't be reproduced or transmitted. It is given at information title and can be modify

HYDRO-ARMOR - Z.A. du Rohou - 29252 PLOUEZOCH - FRANCE
Tél: +33.(0)2.98.67.28.61-Fax: +33.(0)2.98.67.29.23 E-Mail : contact@hydro-armor.fr

