



ES Series 1750 Crane



Our lightweight and super efficient ES Series crane offers a low profile European design with four-function hydraulics.

APPLICATION	Recreational, Light Commercial	
STANDARD FEATURES	<ul style="list-style-type: none"> • Low Profile Design • Smooth Quiet Operation • 4 Function Hydraulics (Luffing, Boom Extension, Rotation, Winch) • 24V DC Power Unit 	<ul style="list-style-type: none"> • Wireless Control • Proof Tested to 110% Capacity • ALEXSEAL Yacht Coating • Amsteel Blue™ Synthetic Rope
OPTIONAL FEATURES	<ul style="list-style-type: none"> • Wired Control • Color Match Finish 	<ul style="list-style-type: none"> • Custom Specifications Available Upon Request
MOUNTING OPTIONS	<ul style="list-style-type: none"> • Standpipe 9' Standard • 16" x 19" Round Base 	<ul style="list-style-type: none"> • 24" x 24" Square Base • 24" x 30" Aluminum HPU Base
HOSES	16' Standard - Available in 5', 8', 22', and Custom Length	



ISO 9001:2008



**PROUDLY MADE IN
NORTH AMERICA**



**STEELHEAD
MARINE**

43676 Progress Way, Chilliwack, BC V2R 0C3
604.607.0091 | **Toll Free:** 1.800.770.0455
info@advantecglobal.com | steelheadmarine.net

ES Series 1750 Crane

MODEL	MAXIMUM LIFT	EXTENDED REACH	HOIST HEIGHT	WEIGHT	RETRACTED LENGTH	IDEAL FOR VESSELS
ES1750	1750 lbs 794 kg	12' 3.7 m	20' 6.0 m	650 lbs 295 kg	7' 2.13 m	70' Plus 21.3 m Plus

CAPACITY	REACH	WEIGHT	HOIST CABLE	CABLE SAFETY FACTOR	HOIST TRAVEL	WINCH TYPE	OPTIONAL HYDRAULICS
1750 lbs 794 kg	12' 3.6 m	630 lbs 285 kg	5/16" Amsteel	9:1	20' 6 m	Linear	Luffing Extension Rotation Winch

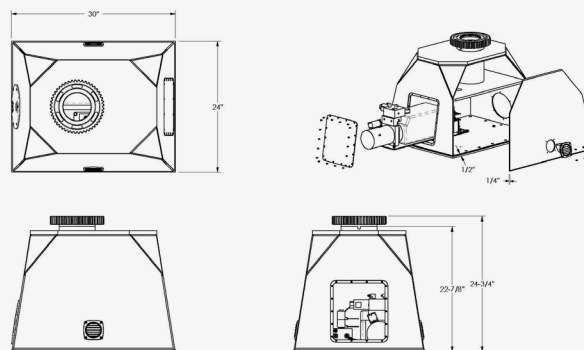
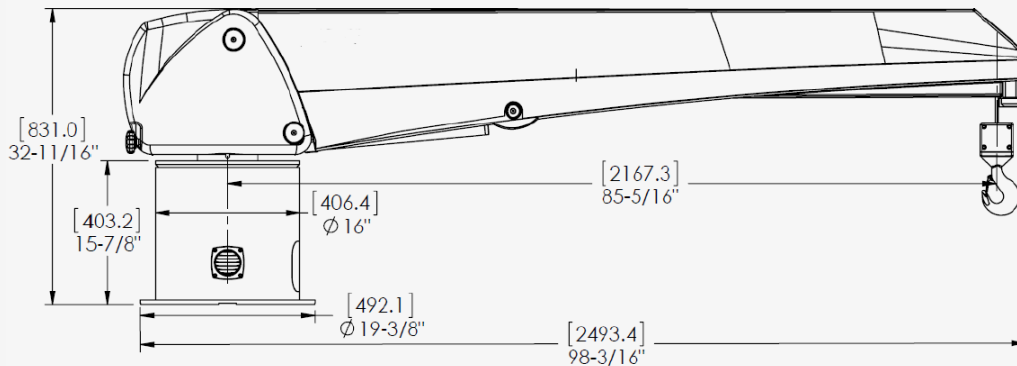

ISO 9001:2008
**PROUDLY MADE IN
NORTH AMERICA**