

EDSON®

Traditional Steering Systems & Accessories



www.edsonmarine.com

Traditional Steering Wheels

These beautifully crafted wheels are designed to provide years of service and pleasure to the boat owner who appreciates fine workmanship. For yachts, work boats or fishing boats, all wheels are individually handmade from thoroughly seasoned stock and the highest quality marine-grade bronze and aluminum. Teak is carefully selected for matching grain and color. Rims and felloes are rigidly secured by stainless fastenings with holly bungs.



Classic Teak Yacht Wheel

Edson's Classic Teak Yacht Wheel is the original. In production for over 125 years, this is a wheel that belongs on any classic yacht or stately passagemaker.

- Offshore-quality wheel.
- Solid teak spokes and felloes rigidly secured with stainless fasteners and holly bungs.
- Hub is available in highly polished and chrome plated bronze.
- Delivered fully varnished.
- 1"/2.5 cm straight bore only.

Order #601

Specify Bronze(BR) or Chrome(CH) Hub
(See ordering guide for sizes)



Teak Yacht Wheel w/ Teak Rim

Edson's Teak Yacht Wheel combines the beauty of the traditional teak wheel with the functionality of a destroyer wheel.

- Laminated 1" dia. Teak Destroyer-type rim installed with stainless fasteners and holly bungs on the solid teak spokes.
- Hub is available in highly polished and chrome plated bronze.
- Delivered with varnished inner rim and spokes. Outer rim is unfinished, ready for each individual's preferred finish.
- 1"/2.5 cm straight bore only.

Order #603

Specify Bronze(BR) or Chrome(CH) Hub
(See ordering guide for sizes)



Bronze Wheel w/ Teak Handles

Edson's Bronze Wheel with Teak Handles adds distinction to any traditional boat.

- Manufactured in Edson's own foundry.
- Made of solid bronze.
- Hand-machined and polished.
- Features varnished teak handles.
- 1"/2.5 cm straight bore only.

Order #602BR

(See ordering guide for sizes)



Tan Character Wheel

Edson's Character Wheels are patterned after the traditional heavy cast iron wheels.

- Manufactured in Edson's own foundry.
- Made of lightweight 356 aluminum.
- Heat-treated to T-6 hardness.
- Feature tan baked-on urethane powder coating and varnished teak handles.
- 1"/2.5 cm straight bore only.

Order #688

(See ordering guide for sizes)



See Edson's Full Marine Catalog for Additional Steering Wheels

Commercial Bronze Wheel

Edson's Commercial Bronze Wheel. Simplicity is the keynote for this rugged wheel.

- Teak handles and a tumbled bronze finish.
- Measures 19"/48 cm tip to tip.
- Provided with 5"/12.7 cm varnished teak handles.
- Available with either a standard 3/4"/1.9 cm taper or a 1"/2.54 cm straight bore.
- Hub thickness is 1 1/8"/2.9 cm.

Tapered Bore – Order #971-19-750T
Straight Bore – Order #971-19-100S



EDSON TRADITIONAL WHEEL ORDERING GUIDE

Wheel Size Inches (cm)	Teak Wheel Order #	Bronze Wheel Order #	Teak Rim Wheel Order #	Character Wheel Order #
20" (50.8 cm)	n/a	602BR-20	n/a	688-20
22" (55.8 cm)	n/a	602BR-22	n/a	n/a
24" (60.9 cm)	601CH or BR-24	602BR-24	n/a	n/a
25" (63.5 cm)	n/a	n/a	n/a	688-25
26" (66.0 cm)	n/a	602BR-26	603CH or BR-26	n/a
28" (71.1 cm)	601CH or BR-28	602BR-28	n/a	n/a
30" (76.2 cm)	n/a	602BR-30	603CH or BR-30	688-30
32" (81.2 cm)	601CH or BR-32	n/a	n/a	n/a
34" (86.1 cm)	n/a	n/a	603CH or BR-34	n/a
35" (89 cm)	n/a	n/a	n/a	688-35
36" (91.4 cm)	601CH or BR-36	n/a	n/a	n/a
38" (99.0 cm)	n/a	n/a	603CH or BR-38	n/a

n/a - wheel not available in this size. All Wheel Hubs have 1" Straight Bore 2 3/8" Long, 1/4" Keyway

Brass & Stainless Wheel Nuts

Attention to detail is the keynote of these Edson Wheel Nuts. Available in highly polished Investment Cast 316 Stainless or traditional Polished Brass. Measure your steering shaft thread for the correct size (1"-14 is standard size since 1979).

- Stainless Wheel Nut with 1"-14 Shaft Threads - Order #673ST-1-14**
- Stainless Wheel Nut with 5/8"-18 Shaft Threads - Order #673ST-5/8-18**
- Stainless Wheel Nut with 3/4"-10 Shaft Threads - Order #673ST-3/4-10**
- Brass Wheel Nut with 1"-14 Shaft Threads - Order #673BR-1-14**
- Brass Wheel Nut with 5/8"-18 Shaft Threads - Order #673BR-5/8-18**
- Brass Wheel Nut with 3/4"-10 Shaft Threads - Order #673BR-3/4-10**



Stainless Wheel Nut
#673ST



Brass Wheel Nut
#673BR

Wheel Hubs

Make your own traditional mahogany or teak wheels. Available in polished or chrome plated bronze castings. Two-piece design allows for easy assembly.

See Ordering Guide.

WHEEL HUB ORDERING GUIDE

For Wheels Sizes:	Bronze Hub	Chrome Hub	Hub O.D.	No. of Spokes	Spoke Size
20" /50.1 cm - 26" /66 cm	Order # 667BR-2	Order # 667CH-2	4" (10.2 cm)	6	1.25" (3.2 cm)
28" /71 cm - 34" /86 cm	Order # 667BR-4	Order # 667CH-4	5 1/2" (13.9 cm)	8	1.375" (3.5 cm)
36" /91.4 cm - 42" /106.7 cm	Order # 667BR-6	Order # 667CH-6	6" (16.5 cm)	8	1.375" (3.5 cm)



Chrome Hub
#667CH



Bronze Hub
#667BR

Teak Handles

These varnished teak handles can be used on home built wheels to replace original handles for a finished look. Complete with 3/8"-16 stainless carriage bolts. These are the same Handles as those used on Edson's #602, #688 and #971 Traditional Wheels.

- 3 1/2" Teak Handle w/Stainless Carriage Bolt - Order #882-350**
- 4" Teak Handle w/Stainless Carriage Bolt - Order #882-400**
- 4 1/2" Teak Handle w/Stainless Carriage Bolt - Order #882-450**
- 5" Teak Handle w/Stainless Carriage Bolt - Order #882-500**



Teak Handles
#882

Wheel Adapters

Edson's Wheel Adapter is a real problem solver. Made of brass and finished with a stainless locking pin and a 1/4" stainless wheel key, the adapter is ideal for installing Edson wheels on other steerers. It's simple and it's strong. Be sure to tell us the make and model of your steerer. Call Edson Customer Service and request Engineering Bulletin EB-95-214-2 for information on the correct adapter for your steerer. Suitable for wheels up to 30" diameter.
Order Part No. 698 (See Price Page).



Part No. 698 Wheel Adapters
For Wheel Adapters Data Sheet EB-95-214, write or call Edson Customer Service.

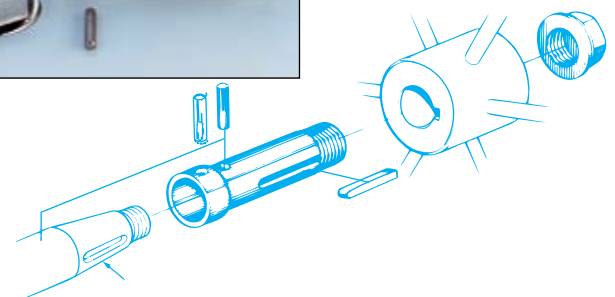

Most Popular Sizes:

- #698-A-306-1** 3 1/2" taper per foot; 5/8"-18 thread (Standard Morse Taper)
- #698-A-306-2** 3/4" taper per foot; 1/2"-20 thread (Standard Teleflex Taper)
- #698-A-338** 3/4"-16 thread; slight taper
- #698-A-340** 3/4" straight shaft
- #698-A-639** 3/4" taper; 5/8"-18 thread

Rack and Pinion Steerers

- Powerful, compact and sensitive steerers.
- Provides positive rudder feedback.
- Rugged construction of bronze alloys and stainless steel.
- 1" Stainless Wheel Shaft fits all Edson Steering Wheels.
- Available for Transom-Hung or Inboard Rudders.

Contact Edson for help in designing the right rack and pinion for your boat. Just send us the top and side view construction drawings of your boat. If they are not available, a simple sketch with dimensions and a photograph will do.

INSTALLATION GUIDELINES: For comfortable, reliable steering the top of the wheel should be located about 32" (81.3 cm) up from the cockpit sole. The seat should be low enough so the helmsman's feet are firmly planted on the cockpit floor or other brace.

Boats with rudderposts located low in the cockpit can use the #782 Rudderpost Extender and #675 Coupling to raise the steering assembly to the required height.

MAINTENANCE: Minimal, once a month maintenance will provide years of trouble-free performance. Oil shaft bearings with #30 motor oil. Use a light application of #827 Teflon Lubricant on the gear teeth and contact point of the adjusting arm. Universal joints should be packed in grease and booted. Daily inspection is recommended.

WHEN ORDERING: Please state the Part # and Size of the Rack and Pinion Steerer you are ordering. It is also important to include your type of boat and a description. In the case of inboard steerers, the rudderpost diameter and key size should be included. Also, state the "A" dimension or wheel shaft length that best fits your installation. **NOTE:** The "A" dimension is the distance between the centerline of the rudderpost to the aft side of the wheel. When determining your wheel shaft length, include the thickness of the face of your wheel box, allowing space for an autopilot and/or a brake (#783 Brake requires 2 1/2"). Edson will machine your steerer to fit the rudderpost in your boat if you supply us with the dimensions of your rudderpost and key sizes. **NOTE:** The rudderpost keyway will be located on the quadrant side unless otherwise specified.

Rack & Pinion Steerers for Transom Hung Rudders

Edson's Transom Hung Rudder Steerer is designed for boats up to 38' with outboard rudders. It has 1.6 turns of the wheel through 70° of rudder travel. When used with a 22" diameter wheel it has the same mechanical advantage as a 7 1/2'-long tiller. *Wt. 26 lbs (11.8 kg).*

Order #341-9 (See Selection Guide).

Edson's Heavy Duty Transom Hung Rudder Steerer is for boats up to 48' and will fit rudderstocks up to 3 1/2" thick. It has 2.8 turns of the wheel through 80° of rudder travel and will approximate a 15' long tiller. *Wt. 38 lbs (17.2 kg).*

Order #341-14 (See Selection Guide).

TRANSOM HUNG RACK & PINION STEERERS ORDERING GUIDE

RUDDERSTOCK THICKNESS		STANDARD ORDER #	WEIGHT		HEAVY DUTY ORDER #	WEIGHT	
inches	cm		lbs	kg		lbs	kg
1 1/4	4.4	341-9-175	24	10.9			
2 1/4	5.7	341-9-225	25	11.3	341-14-225	36	16.3
2 3/4	7.0	341-9-275	26	11.8	341-14-275	38	17.2
3 1/4	8.9	341-9-350	28	12.7	341-14-350	40	18.2

NOTE: "Size" is determined by the thickness of the rudderstock. For example, Size 14-225 means a 14" radius steerer for a 2 1/4" (2.25") thick rudderstock. If in doubt about the fit, order the next size up and shim sides of the jaws if necessary. The jaws are drilled when installing.

Angling Your Rudder Shaft

Edson's Shaft Universal and Self-Aligning Bearings are useful for rack and pinion steering installations on boats with heavily raked rudderposts. The #679 Shaft Universal and the #629 Self Aligning Bearings will allow you to change the angle of the wheel shaft by up to 30°. Refer to page 9 for dimensions and ordering information.

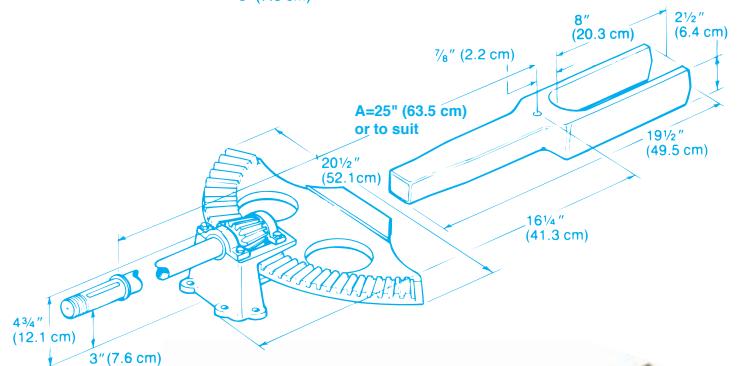
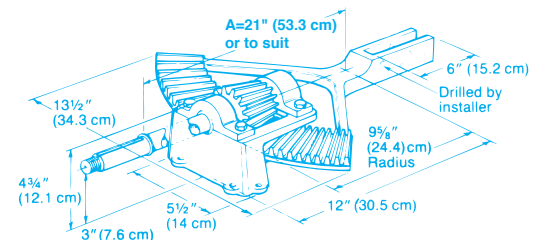
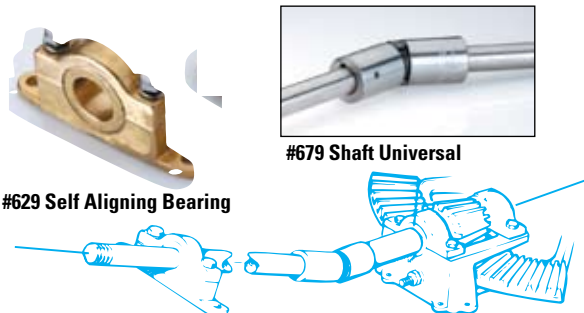

Part No. 341-14

Rack and Pinion Steerers

Forward Mounted Rack and Pinion Steerers for Inboard Rudders

Edson's Forward Mounted Rack and Pinion Steerers are designed for boats up to 48' with inboard rudders that have limited space aft of the rudderpost. These rugged and compact steerers are usually found on the more traditionally designed vessels where rudder feedback is desired.

The #347-9 Steerer will accommodate boats up to 38' with 1.8 turns through 80° of rudder travel. The #347-14 Steerer should be used on boats 38' to 48' in length and has three turns of the wheel through 90° of rudder travel. The rudderpost diameter determines the size of rack and pinion steerers for inboard rudders. Refer to the selection guide below.

Order #347-9 or #347-14 (See Chart).



Part No. 347-9 shown

FORWARD MOUNTED RACK & PINION STEERERS ORDERING GUIDE

Size	Rack Radius		Pilot Bore		Max. Bore		Max. Size Keyway		Weight Each	
	in	cm	in	cm	in	cm	in	cm	lbs	kg
9-24	9	22.86	1	2.54	1 ¹ / ₁₆	4.60	3/ ₈	.95	18	8.2
9-610	9	22.86	1 ¹ / ₈	4.76	3 ¹ / ₂	8.89	1/ ₂	1.27	22	10.0
9-14	9	22.86	3/ ₈	9.21	5	12.70	5/ ₈	1.59	28	12.7
14-24	14	35.56	1	2.54	1 ¹ / ₁₆	4.60	3/ ₈	.95	24	10.9
14-610	14	35.56	1 ¹ / ₈	4.76	3 ¹ / ₂	8.89	1/ ₂	1.27	28	12.7
14-14	14	35.56	3/ ₈	9.21	5	12.70	5/ ₈	1.59	32	14.7

NOTE: Specify rudderpost size, keyway size, and location. (For specials see Part No. 946 on price page.) Weights may vary due to wheel shaft lengths.

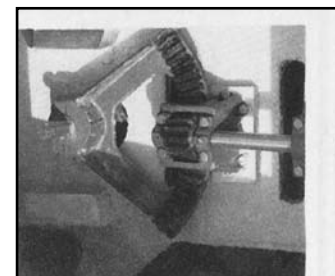
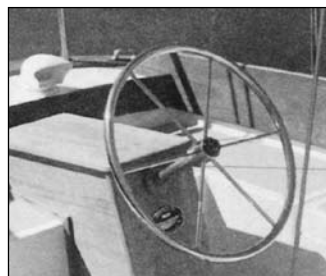

These photos show the simplicity and utility of a Rack and Pinion Installation. Cover box makes an excellent helmsman seat with a hinged top for quick maintenance and inspection.

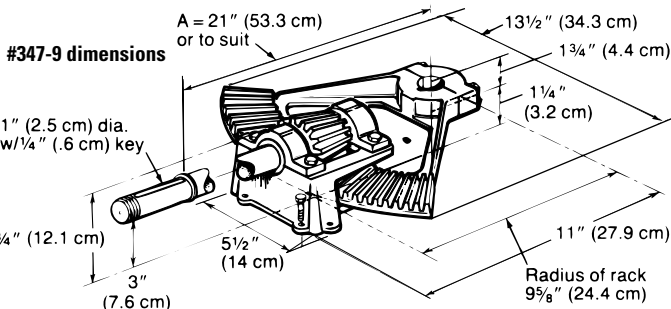

NOTE: The "A" dimension is the distance between the centerline of the rudderpost to the aft side of the wheel.

#347-14 dimensions

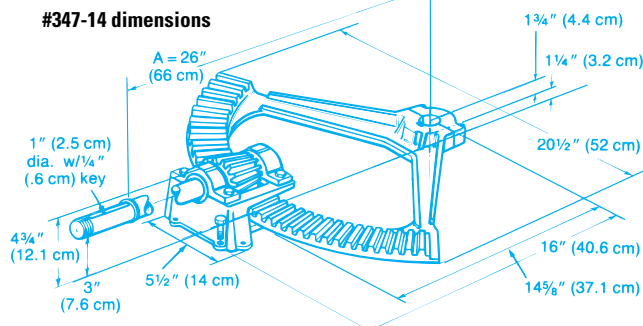

Aft Mounted Rack and Pinion Steerers for Inboard Rudders

Edson's Rack and Pinion Steerers are designed for boatowners who require more cockpit space and rudder feedback and a safe, strong, dependable unit. These aft mounted Rack and Pinion Steerers are designed specifically for vessels that have a minimum of 12" (30.5 cm) of space aft of the rudderpost and where cockpit design requires the wheel to be mounted close to the rudderpost. These steerers take up less than one third of the cockpit space of a tiller, yet the precision cast gears provide the helmsman with all the "feel" and feedback generally associated with a tiller.

Edson's Aft Mounted Rack and Pinion Steerer for use on aft raked rudderposts 1" (2.5 cm) to 2" (5.1 cm) diameter with a maximum key of 3/8" (1 cm) on the rudderpost. If you do not specify bore, the rack will be furnished with a 7/8" (2.2 cm) pilot bore. The "A" dimension on the wheel shaft is standard at 15" (38.1 cm) or is available to, suit. Steerer weight 30 lbs. (13.6 kg). Included is one 1" (2.5 cm) Part No. 629 Bearing.

Order #343-1.

For severely aft raked rudderposts Edson's #344 steerer comes with a #679 Shaft Universal and two #629 1" (2.5 cm) Self-Aligning Bearings. The universal joint included with this steering system allows you to adjust the steering wheel through a 30° arc.

Wt. 34 lbs. (15.4 kg).

Order #344-1.

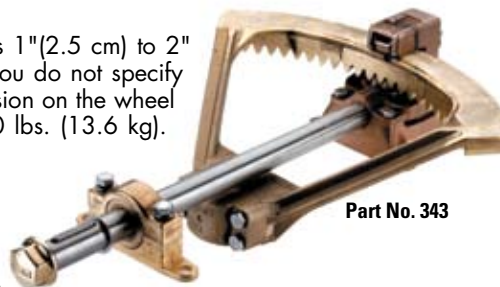
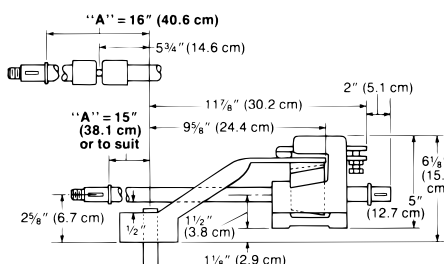

Part No. 343

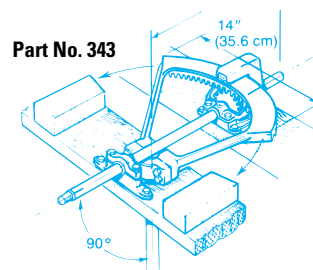

Part No. 343

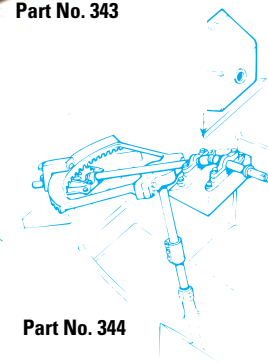

Part No. 344

Worm Gear Steerers

- Classic Design - used for over 100 years on traditional boats.
- Extremely rugged
- No rudder feedback - designed for long-keeled cruisers.
- Rugged construction of bronze alloys and stainless steel.
- 1" Stainless Wheel Shaft fits all Edson Steering Wheels.
- Replaceable Babbitt threads.
- Stub shaft for easy installation of an autopilot.
- Sizes for boats from 35' to 85' (10 to 26 meters).

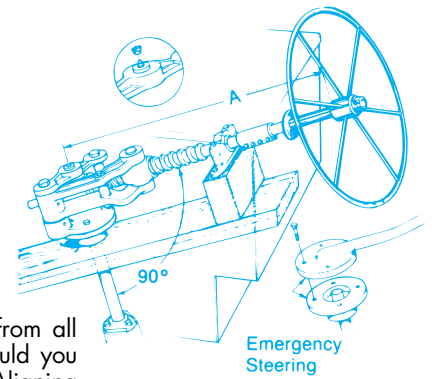

WHEN ORDERING: Worm steerer installations must be well designed and well thought out from all standpoints. The system is mounted at 90° to the rudderpost and is rigid at this point. Should you require a different angle to your wheel, refer to Edson's #679 Shaft Universal. The #629 Self-Aligning Bearing supplied with the gear must be well bolted down to a timber or strong moldment. It is recommended that the top of the wheel rim be 31" (79 cm) to 33" (84 cm) up from the cockpit floor. This will allow you to stand beside the wheel without reaching down to it, and will put the wheel at a convenient height when sitting in back of it or alongside it.

When ordering, advise Edson of the rudderpost bore diameter, keyway size and keyway position - these will be machined by Edson. You will note the standard "A" dimensions on the schematic drawings which relate to shaft length. If a longer or shorter shaft length is required, please advise. *If in doubt as to steerer size or if the boat is heavy, go to the next larger size. Do not compromise on the size.*

MAINTENANCE: For maintenance of all Edson Steering Systems we recommend using #30 oil on all pivot points, and water pump grease on the worm itself and on the grease fitting on the center of the steerer. Check the flange alignment by loosening the four bolts on the top of the steerer and check as you would on a propeller shaft coupling. The 90° angle is extremely important and this point will cause binding if not correctly aligned. Inspect and oil frequently.

WORM STEERER ORDERING GUIDE

Steerer Size	Turns Hard-Over to Hard-Over in 90°	Overall Length of Boat	Rudderpost Bores	Approx. Steerer Weight
Simplex 00	3.25	35' (10.7 m)	1" (2.5 cm) Pilot, 1 1/4" (4.4 cm) max.	33 lbs (15 kg)
Simplex 0	3.75	35-45' (10.7-13.7 m)	1" (2.5 cm) Pilot, 2" (5.1 cm) max.	48 lbs (21.8 kg)
Simplex 1	4.50	45-55' (13.7-16.8 m)	1 1/8" (2.9 cm) Pilot, 2 1/2" (6.4 cm) max.	72 lbs (32.7 kg)
Meteor 1	4.50	45-65' (13.7-19.8 m)	1 1/8" (2.9 cm) Pilot, 2 1/2" (6.4 cm) max.	120 lbs (54.5 kg)
Robinson 2	6.0	65-85' (19.8-25.9 m)	2 1/2" (6.4 cm) Pilot, 3 1/4" (8.3 cm) max.	230 lbs (104.4 kg)

If in doubt as to steerer size, if the boat is very heavy, or if the boat is to be sailed offshore, go to the next larger size. Your naval architect must be consulted as to the final selection. Wheel shaft is sized to fit wheel hubs with 1" (2.5 cm) bores, with 2 1/2" (6 cm) hub lengths and 1/4" (6 cm) keyway.

Meteor Worm Steerer

Edson's Meteor Worm Steerer. This steerer was originally designed for Kaiser Wilhelm's Yacht *Meteor* which was designed to race against *Britannia*. The Meteor is a rugged steerer with "twin" arms for optimum strength and is designed for boats in the 45-65 foot (13.7-19.8 meter) range with room both forward and aft of the rudderpost. *Wt. 128 lbs (58.1 kg).*

Order #390-1.

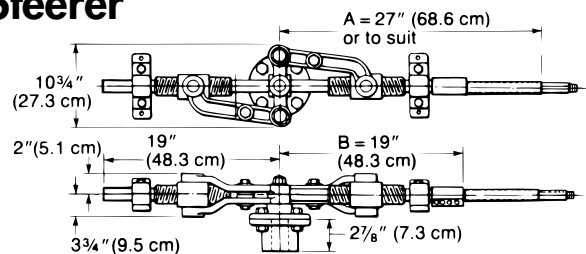

Robinson Worm Steerers

Edson's Robinson Worm Steerer. This steerer features the same rugged construction and "twin" arms as the Meteor Steerer but has larger gears to give you more turns of the wheel hard-over to hard-over. The Part No. 380 Steerer is designed with the "worm" on the aft side of the rudderpost and requires a minimum of 35" (89cm) aft rudderpost. It is recommended for boats in the 65-85 foot (19.8-25.9 meter) range. *Wt. 230 lbs (104.4 kg).*

Order #380-2.

Robinson Worm Steerer. This is virtually identical in design to the Part No. 380 Steerer with the major difference being that the "worm" is located forward of the rudderpost. This makes the Part No. 382 ideal for boats with limited space aft of the rudderpost and is recommended for boats in the 65-85 foot (19.8-25.9 meter) range. *Wt. 230 lbs (104.4 kg).*

Order #382-2.

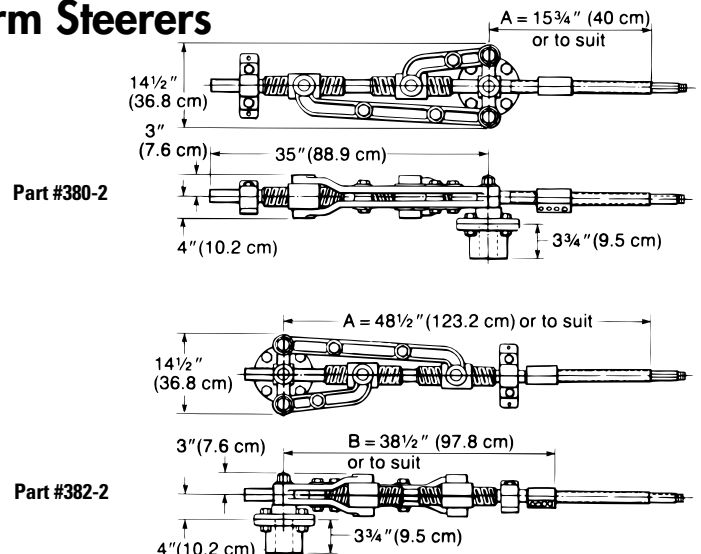

Worm Gear Steerers

Simplex Worm Steerers



Part No. 370-00



Part No. 372-0



Part No. 370-1

WORM AFT OF RUDDERPOST

Edson's Simplex Worm Steerer. Designed for the traditional cruising sailboat. There are three sizes available to suit boats from 22' (6.7 m) to 55' (16.8 m). Part No. 370 Worm Steerer is configured with the actual gear working on the aft side of the rudderpost. Size 00 requires a *minimum* of 14¼" (36.2 cm) and size 1 requires a *minimum* of 19" (48.3 cm) of space aft of the rudderpost, which is shown as the "C" dimension on the chart below.

Order #370 (Specify Size).

Edson's Simplex Worm Steerer. Same as Part No. 370 except that it is supplied with a universal assembly and an extra bearing, and the "A" dimension is about 2½" (6.4 cm) longer than the Part No. 370 fixed shaft steerer.

Order #371 (Specify Size).

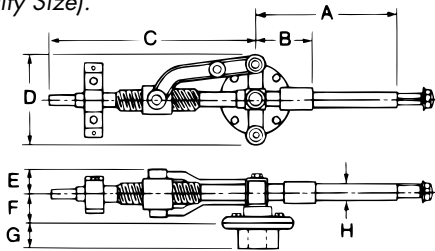

PART #370 DIMENSIONS

Size	A	B	C	D	E	F	G	H
00	14¼" (36.2 cm)	6¼" (15.9 cm)	14¼" (36.2 cm)	7" (17.8 cm)	1¼" (4.4 cm)	2¼" (5.7 cm)	2" (5.1 cm)	1" (2.5 cm)
0	15" (38.1 cm)	7" (17.8 cm)	16" (40.6 cm)	9" (22.9 cm)	2½" (5.4 cm)	¾" (8.3 cm)	2⅝" (5.9 cm)	1" (2.5 cm)
1	16" (40.6 cm)	8" (20.3 cm)	19" (48.3 cm)	13" (33 cm)	2⅝" (5.6 cm)	¾" (9.5 cm)	2¾" (7 cm)	1½" (3.8 cm)

WORM FORWARD OF RUDDERPOST

Edson's Simplex Worm Steerer. Edson engineers designed this steerer with the working gear on the forward side of the rudderpost. This feature allows you to install this steering system on a yacht having as little as 5" – 6" (12.7 cm – 15.2 cm) of space aft of the rudderpost (see "C" dimension in chart below), depending on the size of the worm gear.

Order #372 (Specify Size).

Edson's Simplex Worm Steerer. Same as Part No. 372 except that it is supplied with a universal assembly and an extra bearing and the "A" dimension is about 2½" (6.4 cm) longer than the Part No. 372 fixed shaft steerer.

Order #373 (Specify Size).

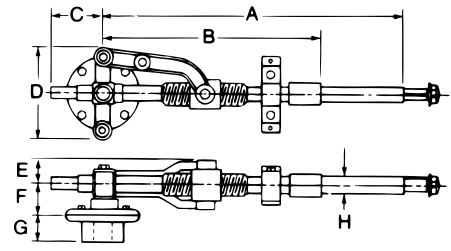

PART #372 DIMENSIONS

Size	A	B	C	D	E	F	G	H
00	24¼" (61.6 cm)	16¼" (41.3 cm)	4½" (11.4 cm)	7½" (19.1 cm)	1¾" (4.4 cm)	2¼" (5.7 cm)	2" (5.1 cm)	1" (2.5 cm)
0	26" (66 cm)	18" (45.7 cm)	5" (12.7 cm)	9" (22.9 cm)	2½" (5.4 cm)	¾" (8.3 cm)	2⅝" (5.9 cm)	1" (2.5 cm)
1	29" (73.7 cm)	21" (53.3 cm)	6" (15.2 cm)	13" (33 cm)	2⅝" (5.6 cm)	¾" (9.5 cm)	2¾" (7 cm)	1½" (3.8 cm)

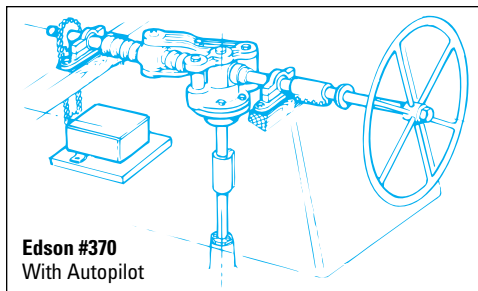

Edson #370
With Autopilot

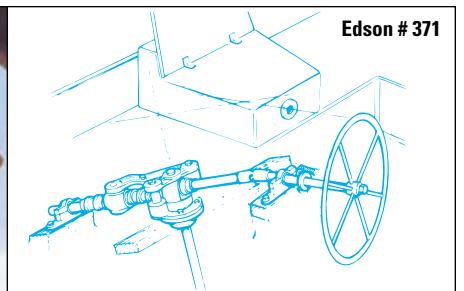

Edson #371

Three typical Simplex Worm Steerer installations

INSTALLATION: The following guidelines should be observed when installing an Edson Worm Steerer:

- 1.) Make sure that the height of the top of the wheel rim is approximately 32" (81.3 cm) off the cockpit sole.
- 2.) Design a helmsman's seat to cover and protect the worm gear and that allows easy access to the gear for inspection and maintenance. The height of the helmsman seat should allow you to firmly plant your feet on the cockpit sole so you do not cut off the circulation in your legs.
- 3.) When installing the rudderpost flange to the flange on the

worm gear, the alignment is as critical as the alignment of your propeller shaft coupling. You should check with a .002" (.05 mm) feeler gauge. Improper alignment will cause binding at the extreme ends of travel.

WHEN ORDERING: Please supply Edson with the diameter of the rudderpost and the key size. Also, if you would like a shaft length ("A" dimension) shorter or longer than standard, please specify, otherwise we will ship standard length shafts.

Accessories For Geared Steerers

Shaft Mount Brake

Edson's Shaft Mount Brake with Stainless Knob. One of our most popular accessories for wheel steerers, we designed this brake especially for Rack and Pinion and Worm Steerer installations. Its dampening action is especially useful on long runs or when operating under power. It can also be used to hold a boat on course under most conditions, but as a safety feature it can be overridden by the helmsman. The brake mounts on the wheel shaft against the inside forward wall of the wheel box, with the brake knob coming out either side of the box. These brakes are constructed of aluminum and bronze. Each is supplied with a long lasting brake lining, brake shaft and a stainless brake handle. Brake shaft lengths available are 8" (20.3 cm) and 12" (30.5 cm). Special lengths are available on request. For 1" shafts only.

Wt. 2 lbs (.9 kg).

8" Shaft Mount Brake - Order #783ST-8

12" Shaft Mount Brake - Order #783ST-12

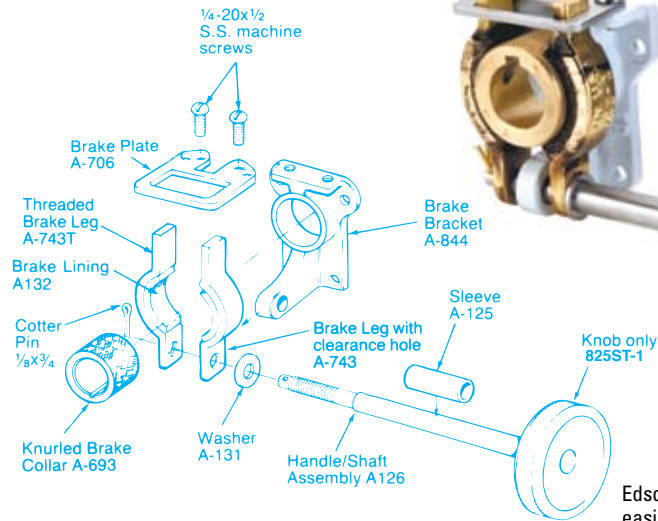

Part #783ST

Edson Brakes are designed to be easily relined to provide you years of service. See Part #316-689 Brake Maintenance Kit on your price page.

Wheel Shaft Faceplates

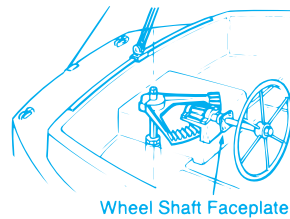

Edson's Wheel Shaft Faceplates. For dressing up Bulkhead and Shelf Steerer installations. #795BR-1 and #795CH-1 are round and mount with four 3/16" flathead fasteners (owner supplied). #795BR-1NB and #795CH-1NB have 1" needle bearings and are designed to give extra support to Bulkhead Steerer #340 with 1" wheel shafts.

FACEPLATE SELECTION GUIDE

Order #	Fits Shafts	Material	Dimensions
795BR-1	1" (25.4 mm)	Bronze	3/4" (82.6 mm)
795CH-1	1" (25.4 mm)	Chrome	3/4" (82.6 mm)
795BR-1NB	1" (25.4 mm)	Bronze	3" x 3/4" x 1/4" Deep (76.2 x 82.6 x 31.7 mm)
795CH-1NB	1" (25.4 mm)	Chrome	3" x 3/4" x 1/4" Deep (76.2 x 82.6 x 31.7 mm)

Compass Pedestal

Edson's Compass Pedestal provides an excellent location for mounting compasses on boats having a Rack & Pinion or Worm Steerer, or even a tiller. Makes a great place to mount Edson Pedestal Accessories such as Guards, Tables, Drink Holders, Engine Controls and Instrument Housings. Constructed of aluminum with durable, glossy-white baked on urethane coating. Standard height is 22", special heights available. For mounting bolts see #646 on the price page.

Wt. 7.5 lbs (3.4 kg).

Compass Pedestal - Order #317-5.



The Island Packet above shows a typical installation of the Edson #317 Compass Pedestal.

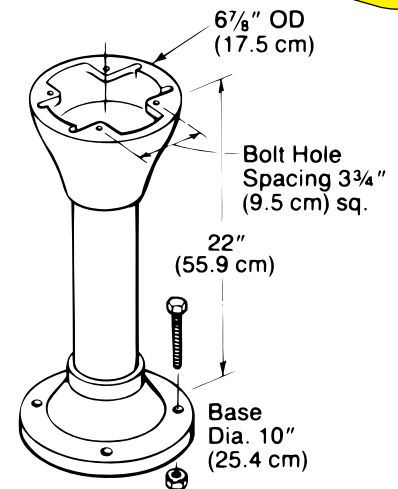

See Page 12 for Binnacle Compasses

Accessories For Geared Steerers

Edson's Self Aligning Bearing. Rugged all bronze bearing designed to take rudderpost loads as well as for Steerers and Rack and Pinion shaft bearings when used in conjunction with Part No. 679 Shaft Universals. Very good for all low speed rotating shafts where alignment is a problem (not to be used on propellers on high speed shafts). Part No. 629 Self Aligning Bearings are available in sizes 1" (2.5 cm) to 2" (5.1 cm). See price pages for all available sizes.

Weights range from 1.5 lbs (.7 kg) to 5.25 lbs (2.9 kg).

Self Aligning Bearings - Order #629A or 629B.

Self Aligning Bearing

#629A
 Sizes available from 1" (2.5 cm) to 1 1/2" (3.8 cm) diameter. Weight 2 lbs (.9 kg).



#629B
 Sizes available from 1 1/2" (3.8 cm) to 2" (5.1 cm) diameter. Weight 6 lbs (2.7 kg).

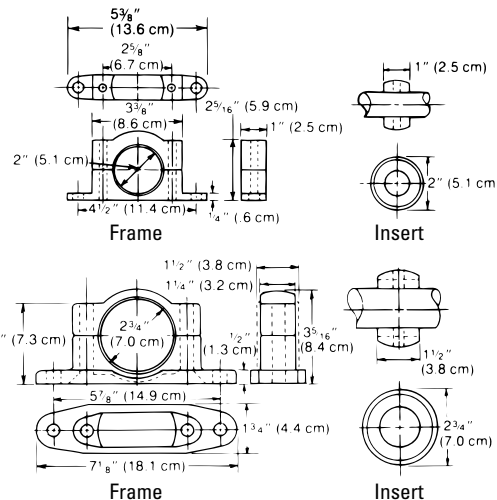

Rudderpost Extender

Edson's Rudderpost Extender. A shaft extension for Rack and Pinion and Worm Steerers where the existing rudderpost is too low in the cockpit. These Extenders are designed for use with Part No. 675 Couplings. Rudderpost Extenders are supplied with keyways at both ends. Type I Extenders have a uniform diameter along their entire length, and Type II Extenders have two diameters as shown. When ordering, specify type and provide sketch showing all dimensions.

Rudderpost Extender - Order #782, Specify Type I or Type II.

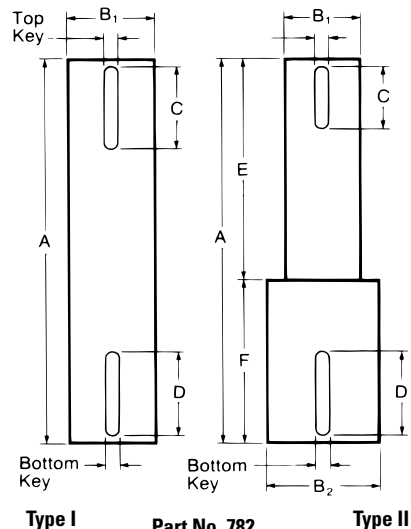

Shaft Universal

Edson's Shaft Universal. For use with Rack and Pinion Steerers and Worm Steerers. Allows the wheel to be tilted to the most comfortable angle when the rudder is extremely raked. For instructions on its use, see Rack and Pinion and Worm Steering sections. Note that a Part No. 629 Self Aligning Bearing must always be used with the universal. The universal is bored for a 1" shaft, machined with a 1/4" keyway, and has a breaking torque of 15,000 inch-pounds. Each end has a set screw. Universals can change shaft angles up to 30°. For maximum life, they should be packed in grease and booted.

Wt. 3 lbs (1.36 kg).
Shaft Universal - Order #679-100



Bronze Shaft Couplings

Edson's Manganese Bronze Shaft Coupling. Especially handy for connecting in-line steering wheel shafts of the same diameter. Also used with rudderpost extenders on Rack and Pinion and Worm Steerer installations where the existing rudderpost is too low. Fits shaft diameters from 1" to 2" (see Price Page). Wt. 3 lbs (1.36 kg).
Bronze Shaft Coupling - Order #675 (Specify Shaft Diameter)

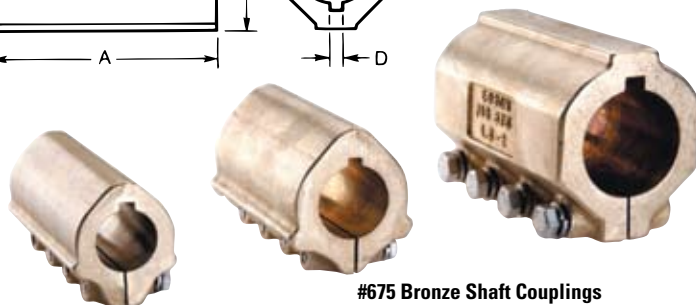
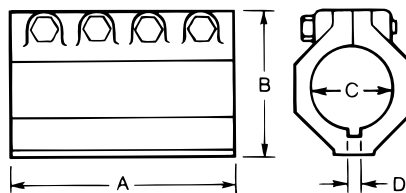

BRONZE SHAFT COUPLING SELECTION GUIDE			
Dim.	Size 1.0 to 1.125	Size 1.25 thru 1.5	Size 1.625 thru 2.0
A	4" (10.1 cm) (1" to 1 1/2" bores)	4" (10.1 cm) (1" to 1 1/2" bores)	5 1/2" (13.3 cm) (1 1/2" to 2" bores)
B	2 1/8" (5.2 cm)	2 1/2" (6.3 cm)	3 1/4" (8.2 cm)
C	1" (2.5 cm) thru 1 1/8" (2.8 cm)	1 1/4" (3.2 cm) thru 1 1/2" (3.8 cm)	1 5/8" (4.1 cm) thru 2" (5.0 cm)
D	up to 1/4" (.63 cm)	1/4" (.63 cm) to 3/8" (.95 cm)	1/4" (.63 cm) to 1/2" (1.3 cm)

Special bore and key sizes upon request (see Price Page).

#675 Bronze Shaft Couplings

Rudder Post Accessories

Bronze Stuffing Box

Combines a rudderpost bearing with an above-the-waterline stuffing box for rudderpost sizes ranging from 1" (2.5 cm) diameter to 4½" (11.4 cm). We recommend fiberglassing the stuffing box/bearing to the top of the tubing when the rudderpost is in place. This can be done easily using alternating layers of fiberglass mat and cloth. This makes the post a structural bearing and will help carry rudder loads with minimal friction. Custom sizes are available on request, but allow additional time.

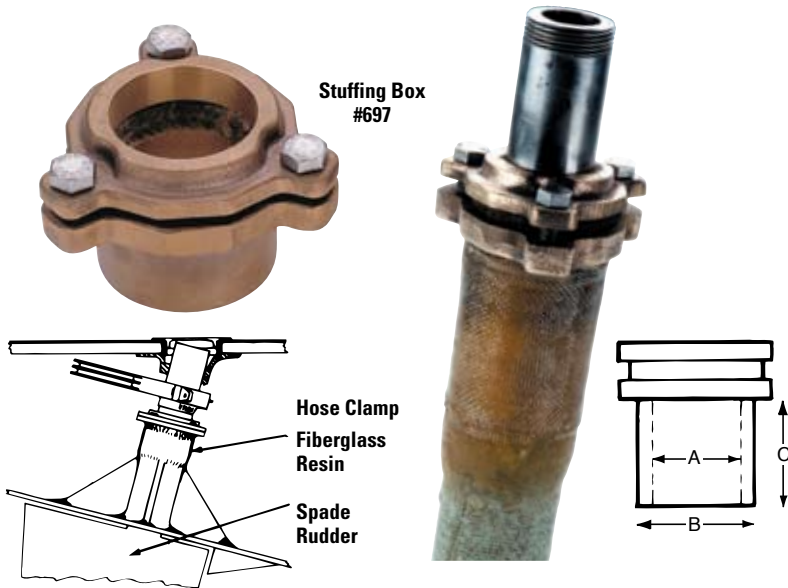

STUFFING BOX ORDERING GUIDE										
For Rudderpost Diameter*	Order #	A**		B		C		Weight		
		in	mm	in	mm	in	mm	lb	Kg	
1"	697-1.0	1	25	2	51	1.25	32	2.5	1.1	
1¼"	697-1.125	1.125	29	2	51	1.25	32	2.5	1.1	
1½"	697-1.250	1.25	32	2	51	1.25	32	2.5	1.1	
1¾"	697-1.375	1.375	35	2	51	1.25	32	2.5	1.1	
2"	697-1.5	1.5	38	2	51	1.25	32	2.5	1.1	
2¼"	697-1.625	1.625	41	2	51	1.25	32	3	1.4	
2½"	697-1.660	1.660	42	2	51	1.25	32	3	1.4	
2¾"	697-1.75	1.75	44	2.44	62	1.25	32	3	1.4	
3"	697-1.875	1.875	48	2.44	62	1.25	32	3	1.4	
3½"	697-1.9	1.9	48	2.44	62	1.25	32	3	1.4	
4"	697-2.0	2.0	51	2.44	62	1.25	32	3.5	1.6	
4½"	697-2.25	2.25	57	3	76	1.25	32	3.5	1.6	
5"	697-2.375	2.375	60	3	76	1.25	32	3.5	1.6	
5½"	697-2.5	2.5	64	3	76	1.25	32	4	1.8	
6"	697-2.860	2.860	73	3.5	89	1.25	32	4	1.8	
6½"	697-2.875	2.875	73	3.5	89	1.25	32	4	1.8	
7"	697-3.0	3.0	76	3.5	89	1.75	44	4.5	2	
7½"	697-3.5	3.5	89	4	101	1.75	44	4.5	2	
8"	697-4.0	4.0	101	4	101	1.75	44	6	2.7	
8½"	697-4.5	4.5	114	5.125	130	1.75	44	6	2.7	

* Metric and Custom sizes available on request.

** 'A' Dimension is actually bored +.03" over rudderpost size for proper clearance.

Bronze Rudder Roller Bearings

Edson's Rudder Roller Bearings carry the rudder weight on rollers. Just bolt or glass in place and rudder drag is virtually eliminated. See Ordering Guide for sizes. Custom sizes available.

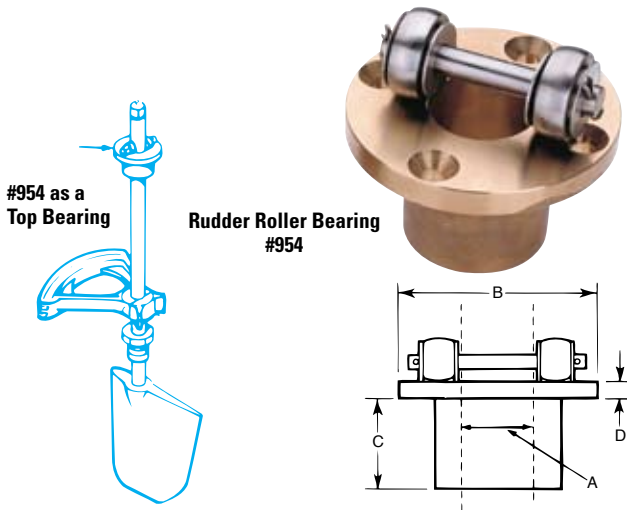

RUDDER ROLLER BEARING ORDERING GUIDE											
For Rudderpost Diameter*	Order #	A**		B		C		D		Weight	
		in	mm	in	mm	in	mm	in	mm	lb	Kg
1"	954-100	1	25	4.375	111	2	51	⅞	11	4	1.8
1¼"	954-125	1.25	32	4.375	111	2	51	⅞	11	4	1.8
1½"	954-150	1.5	38	4.375	111	2	51	⅞	11	4	1.8
1¾"	954-175	1.75	44	4.375	111	2	51	⅞	11	4	1.8
2"	954-1875	1.875	48	4.375	111	2	51	⅞	11	4.25	1.9
2¼"	954-190	1.9	48	4.375	111	2	51	⅞	11	4.25	1.9
2½"	954-200	2.0	51	5.25	133	2	51	⅞	11	5	2.3
2¾"	954-2375	2.375	60	5.25	133	2	51	⅞	11	5.5	2.5
3"	954-2860	2.860	73	5.75	133	2.5	64	⅞	11	7	3.2
3½"	954-2875	2.875	73	6	152	2.5	64	½	13	8	3.6
4"	954-3000	3.0	76	6	152	2.5	64	½	13	8	3.6
4½"	954-3500	3.5	89	7	178	2.5	64	½	13	12	5.4

* Metric and Custom sizes available on request.

** 'A' Dimension is actually bored +.015" over rudderpost size for proper clearance.

Bronze Tiller Head Fittings

Edson's Bronze Tiller Head Fittings are for tillers 1½" wide and for rudder posts of 1" diameter with a ¼" keyway on the forward side -excellent for the aft steering position. They are available in burnished bronze or chrome plated bronze.

Wt. 2.75 lbs (1.3 kg).

Bronze Tiller Head Fitting - Order #965BR-100

Chrome Tiller Head Fitting - Order #965CH-100



Chrome Bronze
Tiller Head Fitting
#965CH-100

Bronze Tiller
Head Fitting
#965BR-100

Leather Spreader Boot Kits



Mariners have been using leather for centuries to prevent premature wear of their sails. Leather will easily outlast and outperform materials of lesser quality, like rubber or tape, when exposed to sun and salt in the harsh marine environment. Edson's custom-cut, hand-stitched Leather Spreader Boots will protect your sails from costly tears and chafe, providing you peace of mind at sea and leaving more money in your pocket. Each kit includes two pre-punched Dove Gray Leather Spreader Boot Covers, heavy waxed polyester thread for lacing, hand-stitching needle and instructions.

LEATHER SPREADER BOOT KIT ORDERING GUIDE

Size	Circumference	Diameter	Order #
Small	3 1/2"	1"	#1401-1
Medium	6 1/2"	2"	#1401-2
Large	9 1/2"	3"	#1401-3

Leather Turnbuckle Covers

Edson's Leather Turnbuckle Covers add a distinctive look while protecting your lines and sails from premature wear. These high quality turnbuckle covers will not crack or deteriorate like plastic and offer more complete coverage, are better looking and longer lasting than tape. Add the look and feel that only comes with leather. Available in Dove Grey, they are attached and removed easily with pre-fastened, industrial grade hood-and-loop strips. Sold individually.



LEATHER TURNBUCKLE COVER ORDERING GUIDE

Size	Fits Turnbuckles	Dimensions	Order #
Small	5/8"	1" x 12"	#1405-12
Medium	1/2"	1 1/2" x 14"	#1405-14
Large	3/4"	1 3/4" x 24"	#1405-24

Leather Shackle Pulls

When hands sometimes they



are cold, tired and wet, need a little assistance with stubborn snap shackles and sticky zippers. Edson's custom-cut "whale tail" Dove Gray Leather Shackle Pulls are durable and the "whale tail" prevents them from coming undone.

Attach them to anything you need to get your hands on quickly. Snap shackles and blocks, zippers on your foul weather gear, luggage zippers, cushion zippers, quick-release

pins - you name it and you will wonder how you got this far without them.

Sold in packages of 10.

Edson Leather Shackle Pulls (Package of 10) - Order #1404-5

Leather Chafing Gear

Edson's Leather Chafing Gear is ideally suited for protecting mooring lines, anchor rodes, dock lines and spreader tips.

BUCK TAN LEATHER

2 1/2 Sq. ft - Order #858TAN-2.5

5 1/2 Sq. ft - Order #858TAN-5.5

11 Sq. ft - Order #858TAN-11

22 Sq. ft - Order #858TAN-22

DOVE GRAY LEATHER

2 1/2 Sq. ft - Order #858GRAY-2.5

5 1/2 Sq. ft - Order #858GRAY-5.5

11 Sq. ft - Order #858GRAY-11

22 Sq. ft - Order #858GRAY-22

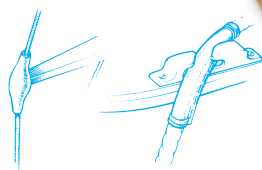

Traditional Boating Accessories

Bronze Dinghy Anchor

Remember those great navy anchors of yesteryear? They were as functional as they were good looking. Now Edson has reintroduced the design as the perfect dinghy anchor. Its cast bronze construction will last for generations. This Bronze Dinghy Anchor weighs 6 pounds (2.7 kg) and comes complete with 33 ft (10 m) of $\frac{3}{8}$ " braided line and a handy stowage bag.

Wt. 8 lb (3.6 kg).

Bronze Dinghy Anchor with Bag and Line - Order #522-6

Bronze Dinghy Anchor without Bag and Line - Order #522-6LL



See Edson's Full Marine Catalog for Additional Marine Accessories!

Anti-Surge Valves

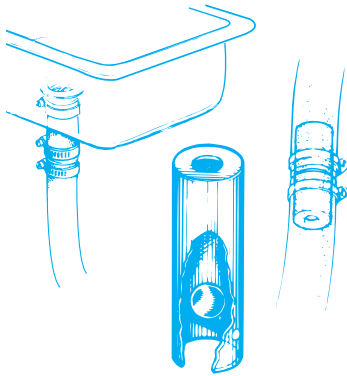

Edson's Anti-Surge Valve controls the flow of drain and bilge water in your boat with a simple floating ball. Use the anti-surge valve wherever the possibility of water backing up in drain lines exists. Ideal for head sinks, galley sinks, and anchor wells that fill when your boat heels over. These valves can also be used in limber holes and grid pan drains to keep bilge water from traveling. Comes complete with two Stainless hose clamps and is available in four sizes.

Anti-Surge Valve for $\frac{3}{4}$ " ID Hose - Order #905-075

Anti-Surge Valve for 1" ID Hose - Order #905-100

Anti-Surge Valve for $1\frac{1}{4}$ " ID Hose - Order #905-125

Anti-Surge Valve for $1\frac{1}{2}$ " ID Hose - Order #905-150



Classic Binnacle Compasses

Binnacle Compass can be mounted directly to the Edson Spacemaker Pedestals using the standard 4-bolt pattern on the top of the pedestal or optional Edson Engine Control Housing. Offered are binnacle models with choices of 5" or 6" dial sizes and optional finishes and materials. They all have 5° increments, built-in compensators, night lighting, full gimbals and 45° lubber lines.

Traditional Binnacle Mount with hood, 5" dials for 335 & 336 Pedestals:

Ritchie Globemaster Stainless (shown) Order #658-D-515-EP
Ritchie Globemaster Brass Order #658-D-515-EX

Traditional Binnacle Mount with hood, 6" dials for 400, 401 & 460 Pedestals:

Ritchie Globemaster Stainless Order #658-D-615-EP
Ritchie Globemaster Brass (shown) Order #658-D-615-EX



Traditional Boating Accessories

Edson One-Step™ Boarding Step

Now Edson makes getting on board from a dingy or dock safer and easier. Cast in aluminum and coated with durable, glossy-white baked on Urethane coating, the Edson One-Step is designed to attach to your lifeline gate stanchions and hang against the side of your boat. It has neoprene bumpers that won't mar your topsides, and the built-in handles give you a secure handhold. Comes complete with 6 ft. of braided line with stainless snap shackles. *Wt. 5 lb (2.3 kg).*

One-Step Boarding Step with Line - Order #520-14
One-Step Boarding Step without Line - Order #520-14LL



Stern Rail Outboard Motor Mount

Built to hold motors up to 15 hp or 100 lbs/45 kg. Convenient cleat and side handles allow you to tie the motor and lock it safely on board. The non-corroding polished 316 stainless bracket with non-skid pad, bolted to the UV stable poly backing board always look ship-shape... no more varnishing. Comes complete with hardware to attach to any standard 1" (2.5cm) or 1 1/4" (3.2 cm) stainless rail. Bottom cleat comes unattached so that it will fit any rail spacing.

Note: 1 1/4" rail version comes complete with anodized aluminum bracket and stainless U-bolt for 1 1/4" railing. *Wt. 10 lb (4.5 kg).*

Outboard Mount for 1" Railing - Order #521-100ST(shown)
Outboard Mount for 1 1/4" Railing - Order #521-125AL

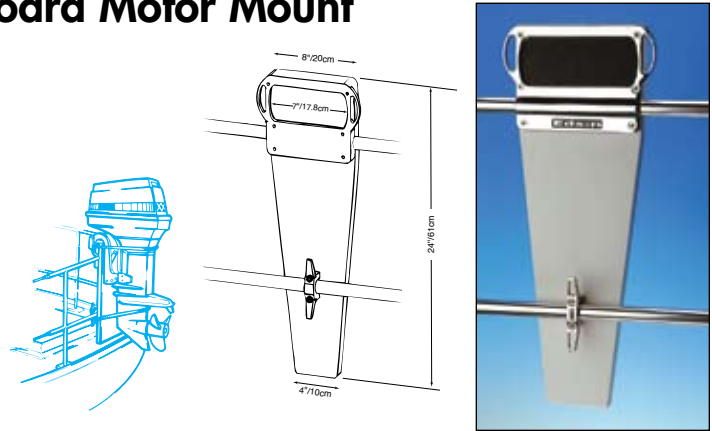

Edson Oar-Loc™

Cast in bronze, this convenient oar locking device is ideal for those who want to leave their oars safely with the dinghy at yacht clubs or public docks. Edson's unique design is easy to operate because the lock is on the top of the seat. You can also lock up your oarlocks by drilling two more holes and putting your oarlocks under your oars. Lock not included. *Wt. 1.35 lb (.6 kg).*

Edson Oar-Loc™ - Order #523-2



Bronze Outboard Brackets

Edson's Bronze Outboard Brackets are designed as an engine mount for use on dinghys and small sailboats. The mounting plate is permanently fastened to the boat's transom. The bracket slides into the plate and is held in place by two stainless steel clips. The outboard motor bracket is available for two different transom angles. Order Size 10 for transoms with 10° angle or Size 3545 for angles of 35° - 45°. Will hold outboards up to 4 HP.

Angled Transom Bracket - Order #951-3545

Straight Transom Bracket - Order #951-010

Angled Transom Bracket
#951-3545

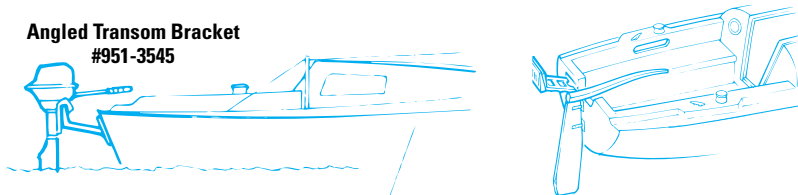

Straight Transom Bracket
#951-010

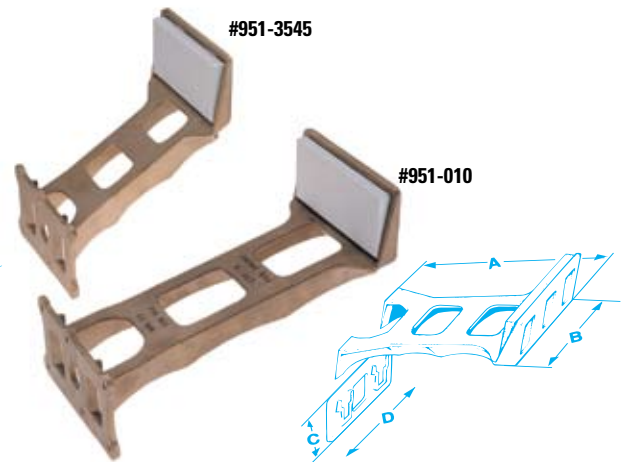
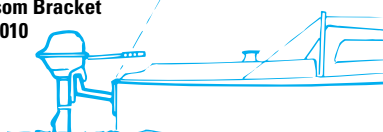

OUTBOARD BRACKET ORDERING GUIDE

Order #	Dimensions				Weight lbs (kg)
	A	B	C	D	
951-3545	9" (23 cm)	8" (20 cm)	4" (10 cm)	8" (20 cm)	8 1/2 (3.9)
951-010	14" (36 cm)	8" (20 cm)	4" (10 cm)	8" (20 cm)	10 1/2 (4.8)

Traditional Bronze Housemarkers

Edson's traditional Bronze House Markers are an excellent way to commemorate any occasion and add a rugged touch of bronze to any surface. When allowed to age naturally, each House Marker will acquire a classic patina.

Cast from hand-carved patterns, these plaques represent six traditional East Coast sailing vessels from the late 19th and early 20th century as well as a Striped Bass, a classic lobsterboat and a nautical compass rose. Each is modeled to-scale, in full relief and shows details of the actual vessel or fish.

The Edson/Anbar Foundry has hand cast and tumbled the bronze plaques to a low-lustre finish ready to be engraved to your specifications. Bronze mounting screws are included and engraving is available in Roman typeface for an additional charge. Please include clear engraving instructions with your order. 15 Characters Maximum, including spaces. Please allow 3-4 weeks for delivery. Engraving charges extra.



Beetle Cat
Order #3205
10" x 12³/₈"



Lobster Boat
Order #3207
14¹/₄" x 8¹/₂"

NEW!



Herreshoff 12¹/₂
Order #3206
9⁷/₈" x 11¹/₂"



Friendship Sloop
Order #3202
10" x 10"

**Great Gift Idea!
Mount on Your
Home Deck!**



Compass Rose
Order #3150
9" Diameter

NEW!



Cape Cod Catboat
Order #3201
9" x 11"



Chesapeake Bay Skipjack
Order #3203
10" x 9¹/₂"



Striped Bass
Order #3204
14¹/₈" x 8¹/₂"



Tankcook Whaler
Order #3200
10" x 9¹/₂"

Edson Diaphragm Pumps

The Edson Diaphragm Pump is the captain's choice for on board applications of bilge pumping, sewage collection, spill clean-up, oil collection and pump-outs of marine sumps, holding tanks and gas tanks. The manual models are often used as emergency manual back up pumps because they can pump a lot of water without power. Available in Bronze or Aluminum in 18 GPM and 40 GPM models.

Edson Pump Features:

- Highest Capacity Manual Pump on the Market - One Gallon Per Stroke (Bone Dry model).
- Up to 30 GPM.
- Self Priming from Dry Starts.
- Handles Solids up to 1 Inch.
- Large Flow Through Inlet and Discharge Passages for Virtual Clog-Proof Operation.
- Reinforced Diaphragms and Valves = Long Life (over 3,000,000 Cycles).
- Available in Marine Grade Red Bronze or Anodized Aluminum.
- Available for 1½" or 2" NPT Ports.
- Built Tough for Years of Service
- Designed Simple for On Board Maintenance.

Portable Pump Kits

Edson Portable Pump Kits are complete pumping systems that include an Edson Pump mounted on a Carrying Board with Handle, Quick Clamp Hose Fittings and a single 20'(6m) length of 1½" hose supplied for optimum configuration by individual. Available in 18 or 30 GPM models.



Bronze Strainers & Foot Valves



- 1½" Bronze Strainer - Order #111BS-150
 2" Bronze Strainer - Order #111BS-200
 1½" Foot Valve/Strainer - Order #130N-150
 2" Foot Valve/Strainer - Order #130N-200

For pump dimensions and specifications visit www.edsonintl.com.

18 GPM Pumps

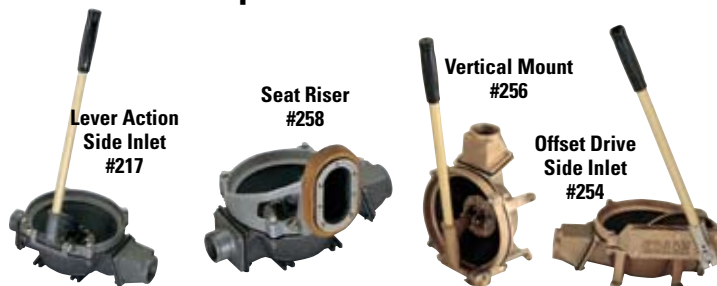

18GPM Manual Diaphragm Pumps are offered in varying configurations to facilitate installation based on where you want to locate the pump on the boat. The #254 Offset Pump facilitates mounting the pump behind a bulkhead, the #256 Vertical Mount Pump allows mounting the pump on a wall and the #258AL is ideal for mounting behind a set riser in the cockpit. An 18" aluminum handle comes with every pump. A 32"/81 cm handle, available in plated or stainless steel is optional.

EDSON 18 GPM PUMP ORDERING GUIDE

Pump Description	Material	Suction, Discharge & Hose Size	Pump Weight	Order #
Lever Action Side Inlet	Aluminum	1½" (3.8 cm) NPT	10lb/4.5kg	217AL-150
	Bronze	1½" (3.8 cm) NPT	32lb/14.5kg	217BR-150
Offset Drive Side Inlet	Aluminum	1½" (3.8 cm) NPT	14lb/6.4kg	254AL-150
	Bronze	1½" (3.8 cm) NPT	35lb/15.9kg	254BR-150
Vertical Mount	Aluminum	1½" (3.8 cm) NPT	10lb/4.5kg	256AL-150
	Bronze	1½" (3.8 cm) NPT	29lb/13.2kg	256BR-150
Seat Riser	Aluminum	1½" (3.8 cm) NPT	10lb/4.5kg	258AL-150
Portable Pump Kit	Aluminum	1½" (3.8 cm) NPT	8lb/3.6kg	165AL-18-150
	Bronze	1½" (3.8 cm) NPT	19lb/8.6kg	165BR-18-150

30 GPM Pumps

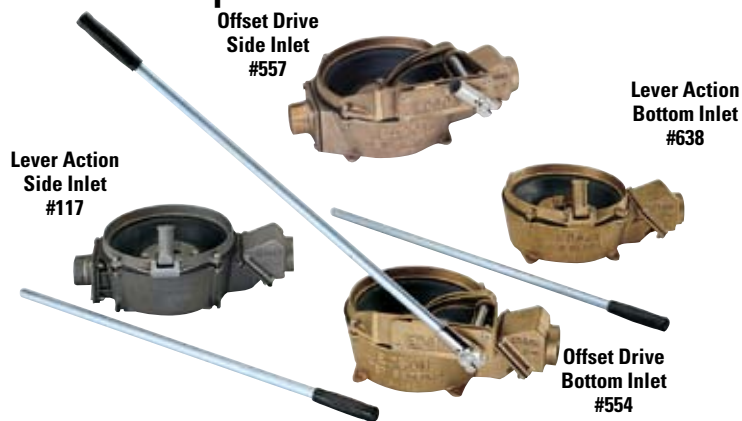

Manual 30 GPM Diaphragm Pumps are available in four models with either side inlet or bottom inlet chambers and lever action or offset drive sockets. The choice of model is based on where you want to locate the pump on the boat. The Offset models facilitate mounting the pump behind a bulkhead. A 32" plated steel handle comes with every pump. It is used for easy stand up pumping. A stainless steel handle is optional.

EDSON 30 GPM PUMP ORDERING GUIDE

Pump Description	Material	Suction, Discharge & Hose Size	Pump Weight	Order #
Lever Action Side Inlet	Aluminum or Bronze	1½" (3.8 cm) NPT or 2" (5.1 cm) NPT	(4.5 kg) (14.5 kg)	117AL 117BR
	Aluminum or Bronze	1½" (3.8 cm) NPT or 2" (5.1 cm) NPT	(6.4 kg) (15.9 kg)	554AL 554BR
Lever-Action Bottom Inlet	Aluminum or Bronze	1½" (3.8 cm) NPT or 2" (5.1 cm) NPT	(4.5 kg) (13.2 kg)	638AL 638BR
	Aluminum or Bronze	1½" (3.8 cm) NPT or 2" (5.1 cm) NPT	(4.5 kg) (13.2 kg)	557AL 557BR
Portable Pump Kit	Aluminum	2" (5.1 cm) NPT	(4.5 kg)	165AL-30



Edson International
 146 Duchaine Blvd.
 New Bedford, MA 02745-1292

Over 150 Years of Engineering Excellence!

In a fine example of "Yankee Ingenuity", Jacob Edson invented the diaphragm pump, and in 1859 established The Edson Corporation in Boston, Massachusetts to manufacture and sell his pump. He continued to invent a wide range of marine products which resulted in significant growth; and in the mid 1930's the company moved to expanded facilities in New Bedford, MA. The Edson Corporation is now recognized as one of the oldest continuously operating businesses in Massachusetts and the United States.

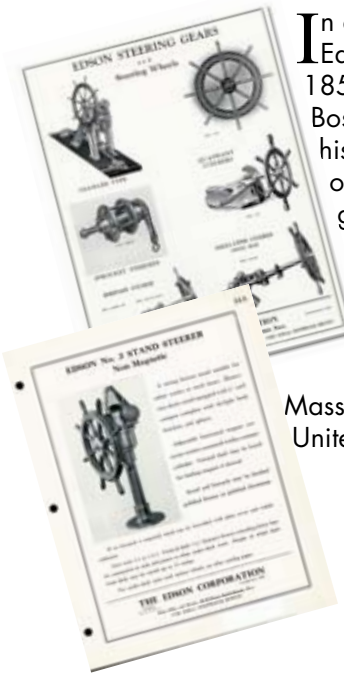

Additional Edson Information



www.edsonmarine.com

www.edsonpumps.com