

**INSTALLATION:** The motor and circuitry are not waterproof. Install PSR in a dry, well ventilated location not more than 10-feet above the water supply. If PSR will have a flooded inlet the pump may be oriented in any position; if PSR must self-prime orientation must be upright.

Mount PSR to a sturdy platform using the four (4) mount feet included. Operation will be quieter if mounted to a solid surface.

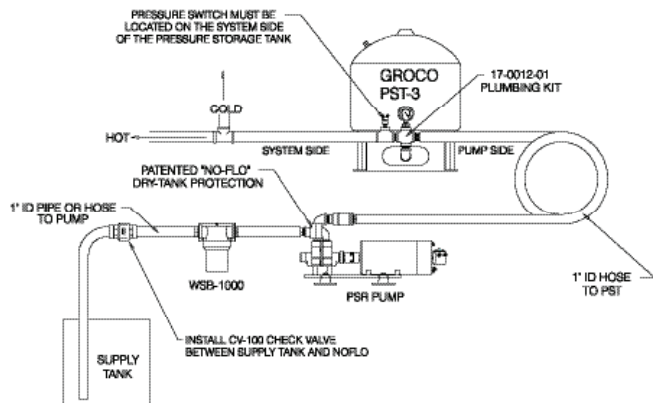

**PLUMBING:** Fasten 17-0012-01 plumbing kit onto the PST (pressure storage tank) with the pressure switch on the system-side of the PST and the hose barb on the pump-side of the PST as shown above. To aid in initial priming, pour water into the pump inlet before connecting hoses to the pump. Plumbing between the pump and the PST must be 1" ID heavily reinforced hose, and must be free of valves, filters, or any other device. Plumbing after the PST may be reduced.

Plumb between the pump and the supply tank with heavily reinforced 1" ID hose, and install WSB-1000 in the inlet line where it is accessible for service and inspection.

Install CV-100 check valve (included) anywhere between supply tank and NOFLO™.

**PRESSURE STORAGE TANK:** PSR requires the use of a Pressure Storage Tank. Use only GROCO® PST-2, PST-3, PST-4 or PST-5. Multiple PSTs may be plumbed in parallel if desired. DO NOT use a single PST-1 because it does not have sufficient storage capacity.

**IMPORTANT:** Before applying power to PSR, the air charge in the PST must be checked and adjusted to 28-30 PSIG. There is an air valve on the tank at the opposite end from the plumbing connection. Remove the protective cap and check and set air pressure with no water pressure present; use a standard tire gauge to check the pressure. Excess pressure can be released by depressing the center of the valve. Use a hand pump such as a bicycle pump to add air if necessary.

**PRESSURE SWITCH CONNECTION:** A 10-foot wire harness is provided to connect between the pressure switch and the terminal block on the motor end cap.

**WATER FILTERS AND PURIFIERS:** We do not recommend the use of filters as they will seriously restrict the flow and pressure you desire. If you choose to utilize such a filter, it must be installed after the PST. DO NOT install a filter between the supply tank and the pump.

**ELECTRICAL:** Do not connect PSR to the boat's bonding system.

Voltage	Breaker
PSR 12V	50-A
PSR 24V	30-A
PSR 32V	20-A

Proper wire size is essential. Refer to the wire size selection information included with this product. For DC models connect positive (+) to the solenoid terminal with the red tag (remove the tag). Connect ground (-) to the bronze stud directly beneath the solenoid. Protect PSR with a dedicated circuit breaker.

**START-UP:** In preparation for start-up, check all plumbing and electrical connections. Open all faucets and shower heads half-way. Apply power at the circuit breaker; the pump will run and should self-prime within 30 seconds. If the pump does not prime within 30-seconds the dry-tank protection system will turn the pump off. Interrupt power at the breaker panel to reset the pump control.

As water flows smoothly from each shower head and faucet, shut it off. When all outlets have been shut off the pump will pressurize the system and shut off. Note that it will take several minutes to fill the PST(s) and the water heater(s).

**DRY TANK SHUT-DOWN:** These are the dry-tank conditions under which your Paragon Pump will turn off.

- \* NOFLO™ has sensed the absence of water at the pump inlet for 30-seconds
- \* The pump has run continuously for 10-minutes

Paragon Pumps are equipped with a patented dry tank protection system called NOFLO™, which senses the presence of water at the pump inlet. Some purified water such as reverse-osmosis water or reclaimed water may not be sensed by NOFLO™. If this happens the pump may turn off even though water is present.

A jumper wire is installed across the NOFLO™ terminals. The jumper disables NOFLO™ and permits the pump to operate with purified waters. Dry running protection is still provided by a built-in 10-minute timer.



To enable NOFLO™ remove the jumper wire. During normal operation NOFLO™ will sense the absence of water and turn the pump off after 30-seconds of continuous dry running. If your Paragon pump ever shuts off when you know that water is present and the pump has not exceeded 10-minutes of continuous running, reconnect the jumper wire to disable NOFLO™.

Interrupt power at the breaker panel to reset the pump control.

**WINTERIZATION:** Freezing will damage your pump and the connected plumbing. To winterize first allow PSR to pump the supply tank(s) dry. Shut off power when the faucets begin to pass air. Disconnect inlet and outlet hoses to drain the connecting plumbing and remove WSB-1000 bowl. Pour an ounce or two of potable alcohol (your favorite scotch will do fine) into the pump. Reconnect the hoses to prevent evaporation. DO NOT use automotive antifreeze to winterize as it may be poisonous.

**MAINTENANCE:** Check the WSB-1000 inlet strainer at least monthly. Check the air charge in the PST at least monthly. This is done with no system water pressure present. With a tire gauge check the air charge. It should be the same as the cut-on pressure of the pump (28-30 psi). Add or remove air as needed before pressurizing the system.

DO NOT lubricate any part of the pump.

### SERVICE NOTES:

- \* Pumps made between S/N 030101-01 and 030615-99 utilized a transducer (identified by stainless steel body and plug-in cable) for on/off pump control. Pumps with transducer may be returned to GROCO for no-charge refit of IPS-51 switch and P-6001-E Control.
- \* Pumps made before S/N 880101 used a 4" diameter "G" series motor, which is no longer available. Pumps made after S/N 880101 use the "J" series motor. If you are replacing a "G" series motor with a "J" series motor, P-7004-D base is also required.
- \* Adjustable pressure switch #69-A may be substituted for IPS-51, but **must not be used aboard gasoline-powered boats.**

Item	Part Number	Description	Qty	Regular	Master
1	P-9020-C	End Cap, after 030801	1		
	P-9020	End Cap, before 030801	1		
2	P-9015	Seal	2	*	*
3	P-9001/9002 Set	Pump Housings	1		
4	2-042	O-Ring, after 851201	1	*	*
	2-041	O-Ring, before 851201	1	*	*
5	P-9009 Set	Bearings	1		
6	P-9014 Set	Impellers	1		*
7	P-9003/4 Assy	Shaft & Eccentrics	1		
8	P-9006	Separator Assy	1		
9	1428X12HS	Screw	4		
1-9	P-9000	Pump Assy	1		
10	P-7006	Spyder only	1	*	*
11	P-7005	Coupling Set	1		
12	P-7004-D	Base	1		
13	(Voltage)-JCE	Motor & Control Assy	1		
14	(Voltage)-J	Motor only	1		
15	P-6001-A	Control before 880101 (NLA)	1		
	P-6001-B	Control 880101-020630 (NLA)			
	P-6001-D	Control 030101-030619 (NLA)			
	P-6001-E	Control after 020101			
16	P-6003 (Voltage)	Solenoid only	1		
17	17-0007-05	Plumbing Kit, Outlet	1		
18	CV-75	Check Valve only	1		
	P-9021-E	(NLA)			
19	PVC-33	3/4" Sch-80 PVC Nipple	1		
20	NOFLO7500	Dry Tank Module only	1		
21	17-0012-01	Remote Plumbing Kit	1		
22	IPS-51	Pressure Switch, UL & CE	1		
	69-A	Pressure Switch, not UL & CE			
23	P-8005-B	Oil Filled Guage	1		
	P-8005-A	Gauge (not oil filled) (NLA)			
NS	P-9005	Seal, before 850101	2	*	*
NS	WSA-1001	Filter Basket	1		*
NS	WSA-1002	Gasket	1		*
NS	P-9007	Impeller Guide only (NLA)	1		
NS	P-9022-B	Mount Feet (4)	1		
	PSR Regular	Service Kit		*	
	PSR Master	Service Kit			*

CONTROL#	ON/OFF	DRY-TANK PROTECTION	COMMENT
P-6001-A	Pressure Switch	Thermal Switch	NLA - see individual parts
P-6001-B	Pressure Switch	Thermal Switch	Between S/N 880101-020630 NLA - See P-6001-E
P-6001-D	Transducer	NOFLO™ + Timer	Between 030101-01 and 300615-99 (no longer available)
P-6001-E	Pressure Switch	NOFLO™ + Timer	After S/N 020101

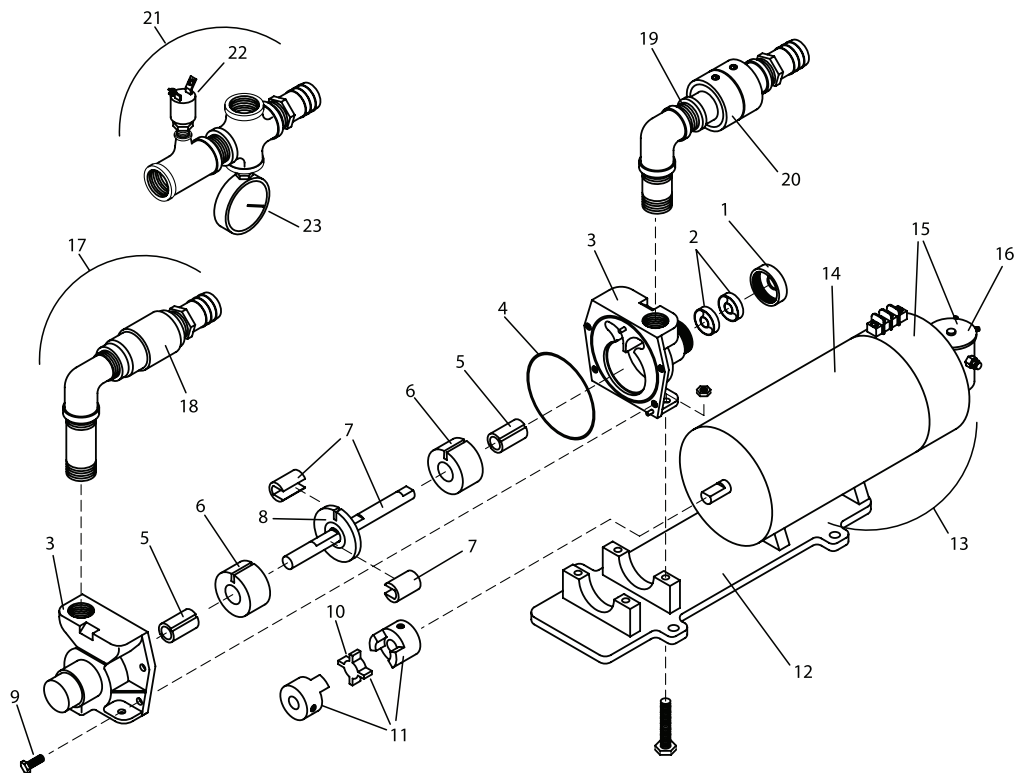

© 1999 GROCO MECHANICAL LABORATORIES, INC. ALL RIGHTS RESERVED.

For service assistance/information call 410.712.4242 and ask for Paragon Service Department. After hours, go to [www.groco.net](http://www.groco.net).