



Photo courtesy of Seaspan

Hydraulic Follow-Up HFU360

The HFU360 is a state-of-the-art electro-hydraulic steering system, providing full follow-up power steering with unmatched smoothness, quietness and accuracy for small to-medium size vessels.

Hydraulic power may be provided by engine-driven or electric motor driven pumpsets. The HFU360 may be controlled by conventional hydraulic helm pumps, by electric jog levers, and / or by an autopilot. The HFU360 does not require any mechanical feedback linkage. It only requires a small and simple electric feedback unit to be attached to the steering tiller.

Should the hydraulic or electric power supply fail a proper manual hydraulic system becomes available automatically instantly connecting the helm pump directly and instantaneously to the main steering cylinders.

The steering cylinders are protected by a double-acting relief valve built into the HFU360. The HFU360 is isolated at all times from excessive rudder forces. A rudder lockvalve positively holds the rudder against creep.

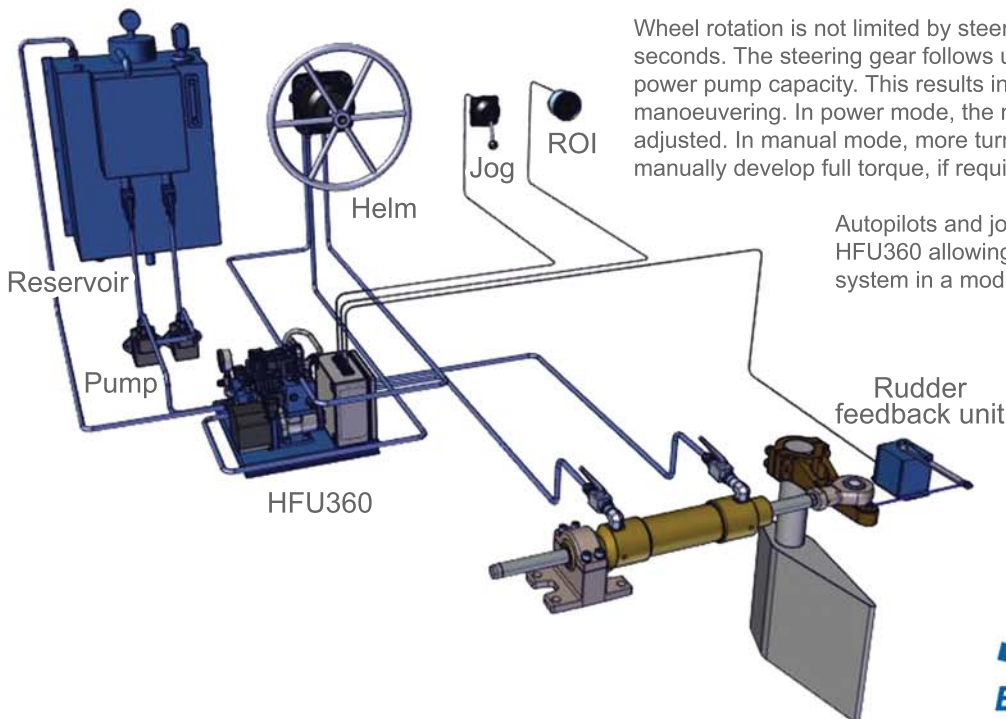

Wheel rotation is not limited by steering gear speed and may be put hardover in a few seconds. The steering gear follows up to this new position at a rate dependent on the power pump capacity. This results in finger tip steering and greater ease of manoeuvring. In power mode, the number of turns from hardover to hardover can be adjusted. In manual mode, more turns are allowed permitting the helmsman to manually develop full torque, if required, with reasonable wheel effort.

Autopilots and jog levers may be electrically connected to the HFU360 allowing for a true customization of the complete steering system in a modular manner.

Descriptions

Features:

- TRUE FOLLOW UP control by means of manual helm pump(s), jog and autopilot
- SLOW-SPEED ACCELERATION AND DECELERATION over first and last five portion of rudder movement for smooth, accurate and silent operation
- TRUE CHANGEOVER to manual steering giving strong and reliable back-up control
- FINGER TIP CONTROL with extreme accuracy
- HYDRAULIC PROTECTION by double reliefs and load-holding valves
- OPTIONAL ELECTRICAL CONTROLS by jog levers or autopilot

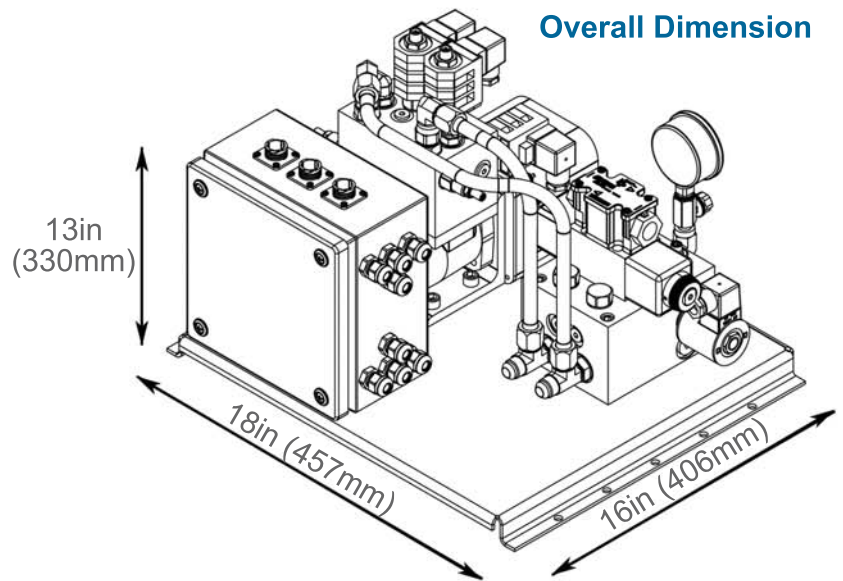

A typical steering system will consist of:

- Steering tiller(s)
- Steering cylinder(s) or T-model Rapson slide actuator(s)
- RFU300 feedback unit(s)
- HFU360
- Hydraulic reservoir
- Engine or motor-driven pump(s)
- Helm pump(s), Jastram H-Model
- Optional jog lever(s), Jastram JOG100
- Rudder order indicator, Jastram ROI

Technical Characteristics:

- Power supply: 24 VDC, 6 amps
- Output flow rate: 8 gpm (max)
- Working pressure: 1500 psi (max)
- Steering modes: FFU, NFU, manual helm and/or autopilot
- Adjustable rudder hardover angle
- Adjustable helm pump wheel turns
- Weight: 55 lbs (24.9 kg)
- Uses standard ISO grade 32 hydraulic oil

Consult your Jastram agent, or the factory, for complete system sizing and quotation

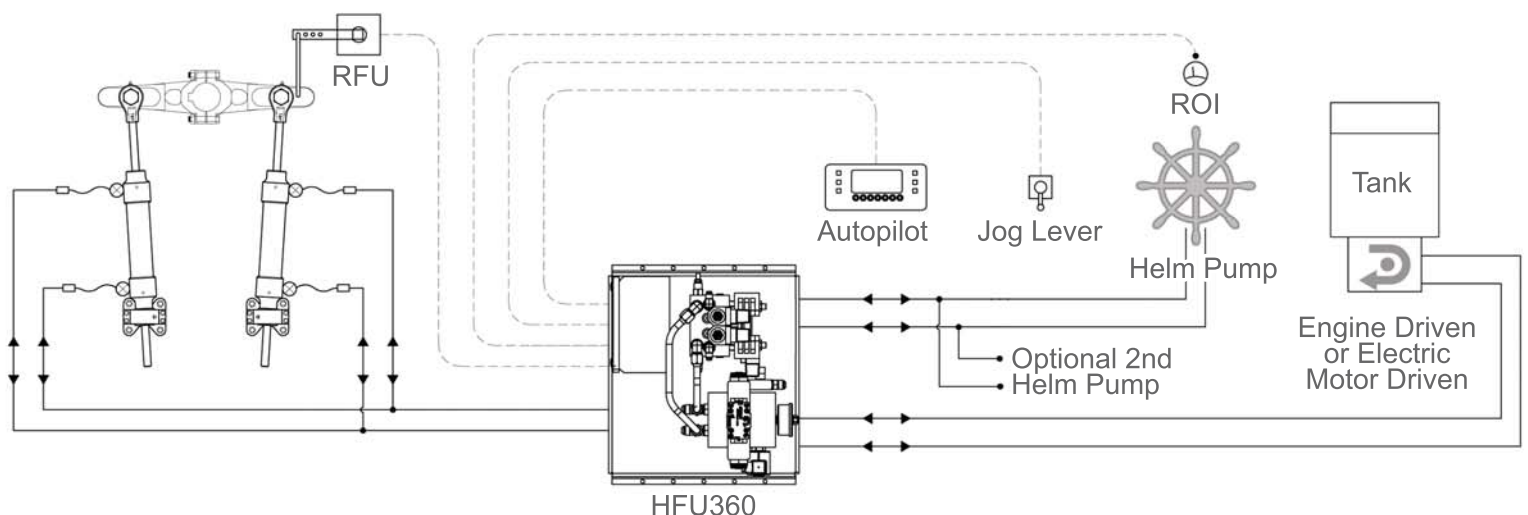

Data is subject to change without notice* BRC01200